



Three Phase Aluminum

MOTOR MODEL:	GX3-AL-TF-184TC-4-B-D-5
FACTORY TYPE:	TXA

NEMA

Premium NEMA Cast Aluminum, TEFC

Torque Speed (T-n) Curve

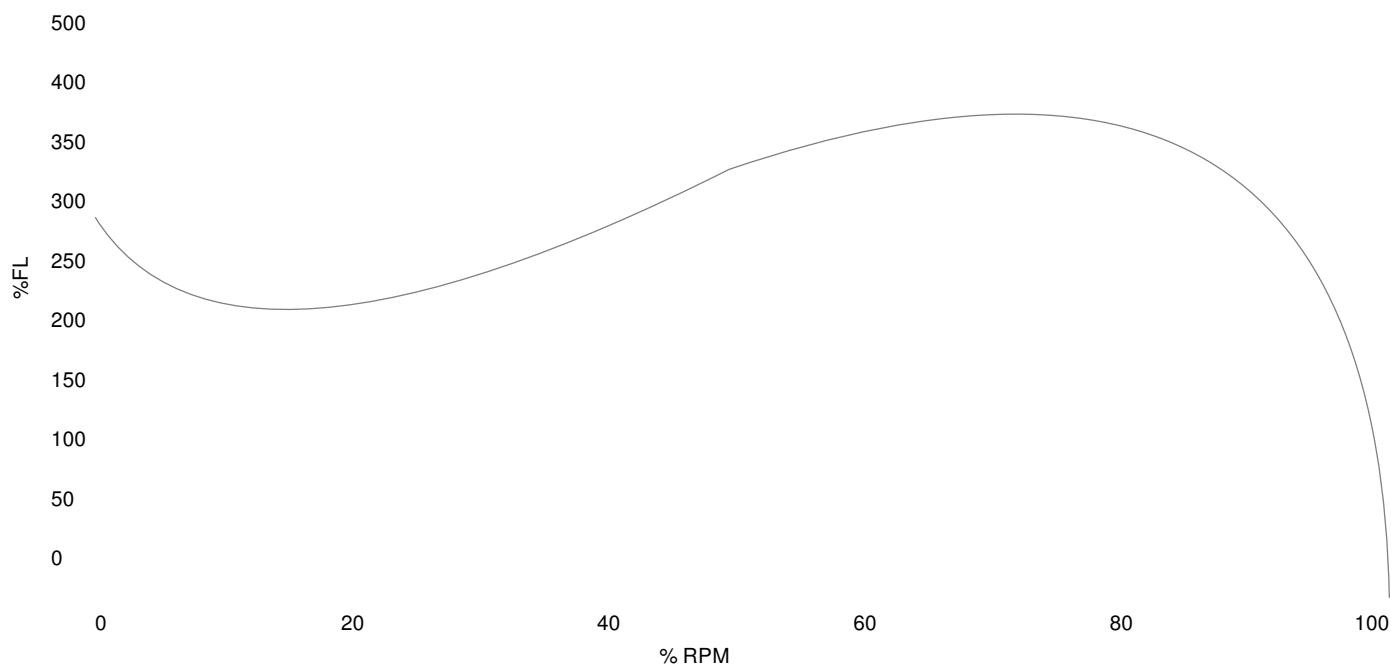

Performance Load Values, High Voltage, 60Hz

Torque Values	Torque lb-ft	% FLT	Performance Values
Locked Rotor Torque	43.512	294.0	Start Configuration
Pull-Up Torque	19.98	135.0	Starting Current (A)
Breakdown Torque	48.988	331.0	No-Load Current (A)
Full Load	14.8	-	No-Load Power Factor

% Load	Horsepower	Current, Amps	Input power, Kilowatts	Speed, RPM	Efficiency	PF
0	-	4.85	0.166	-	-	-
25	1.25	5.569	1.108	1789.5	83.48	0.499
50	2.5	7.3	2.08	1778.8	88.94	0.715
75	3.75	9.51	3.08	1767.0	89.98	0.814
100	5.0	12.1	4.127	1755.2	89.65	0.856
125	6.25	14.98	5.215	1742.0	88.69	0.874

Techtop Industries
 2815 Colonnades Court
 Peachtree Corners, GA 30071
 Tel: 678-436-5540
 E-Mail: info@techttopind.com

MOTOR MODEL:	GX3-AL-TF-184TC-4-B-D-5
FACTORY TYPE:	TXA

Premium NEMA Cast Aluminum, TEFC

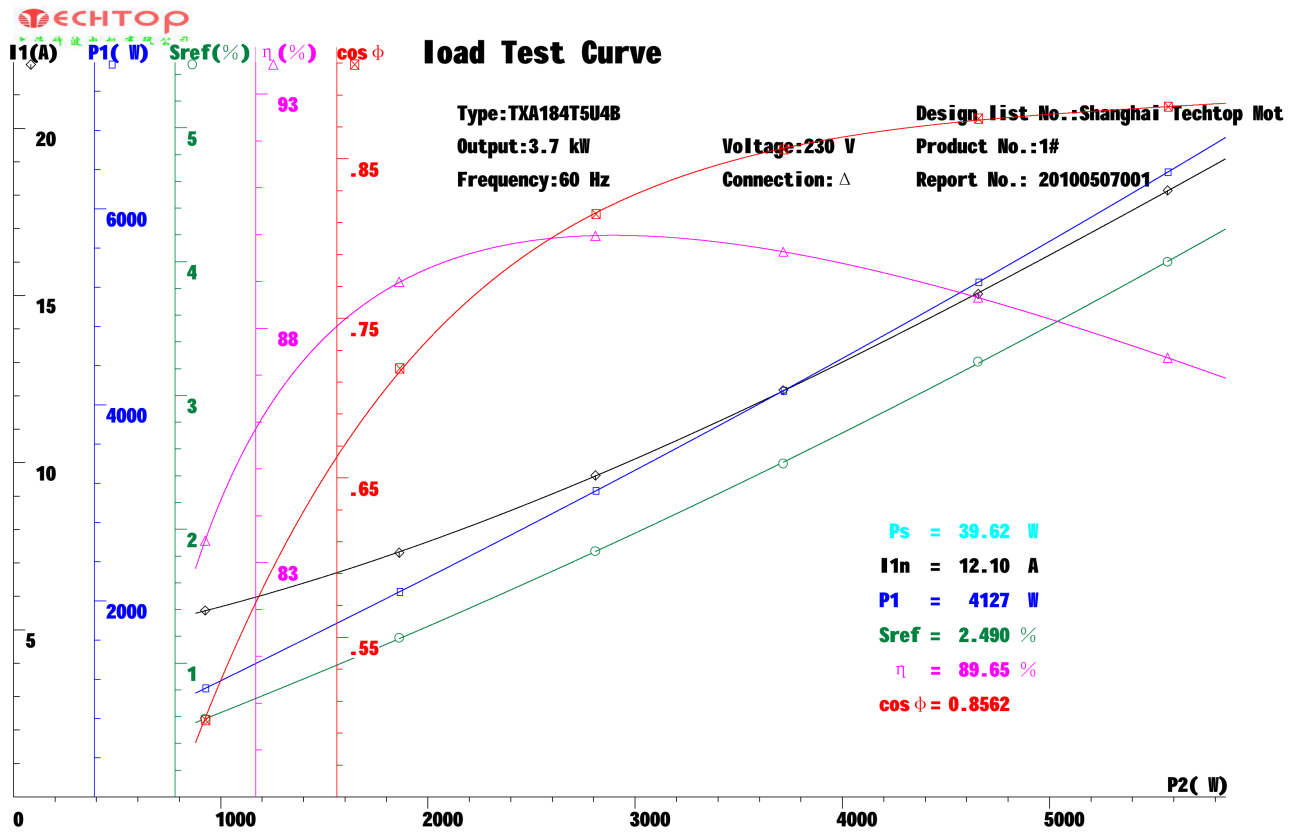



Three Phase Aluminum

MOTOR MODEL:	GX3-AL-TF-184TC-4-B-D-5
FACTORY TYPE:	TXA

NEMA

Premium NEMA Cast Aluminum, TEFC

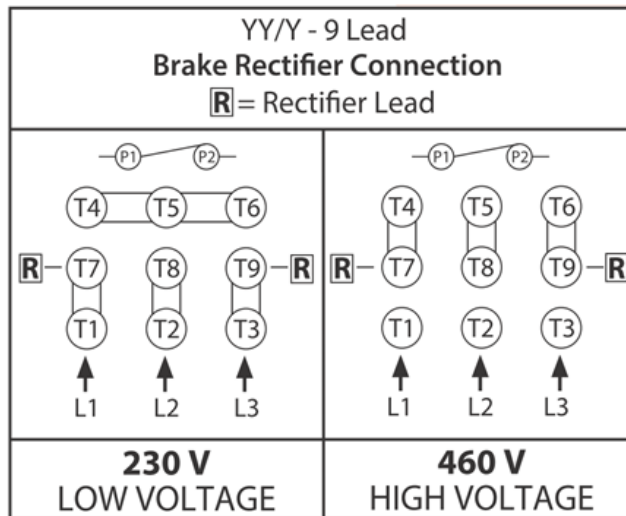

Techtop Industries
2815 Colonnades Court
Peachtree Corners, GA 30071
Tel: 678-436-5540
E-Mail: info@techttopind.com



Three Phase Aluminum

NEMA

MOTOR MODEL:	GX3-AL-TF-184TC-4-B-D-5
FACTORY TYPE:	TXA

Premium NEMA Cast Aluminum, TEFC

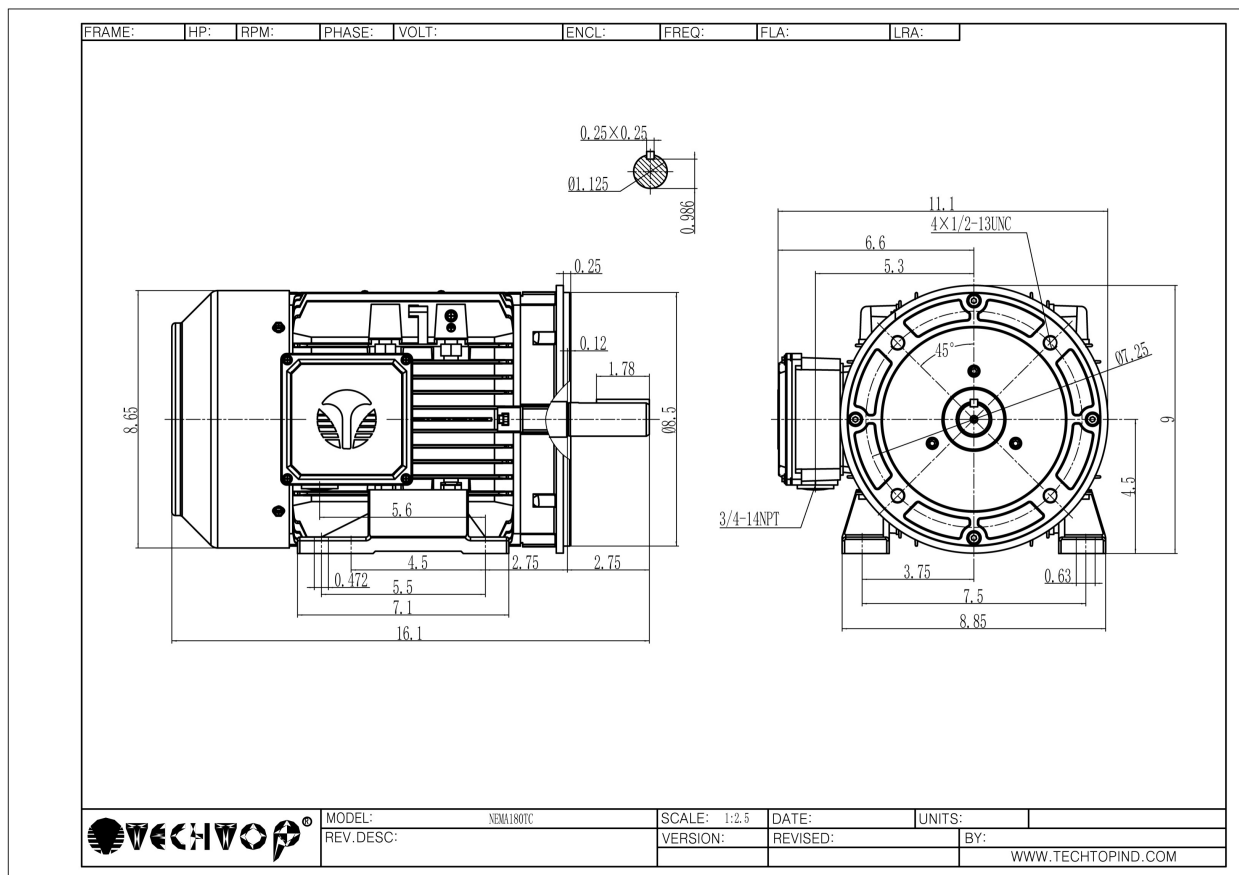

Techtop Industries
 2815 Colonnades Court
 Peachtree Corners, GA 30071
 Tel: 678-436-5540
 E-Mail: info@techttopind.com