



# SERVICE PARTS LIST

**BULLETIN NO.**  
**54-40-6600**

SPECIFY CATALOG NO. AND SERIAL NO. WHEN ORDERING PARTS		REVISED BULLETIN	DATE
<b>M18™ FUEL™ 9" Cut-Off Saw</b>			Feb. 2020
CATALOG NO.	<b>2786-20</b>	STARTING SERIAL NO.	<b>K96A</b>
		WIRING INSTRUCTION <b>SEE PAGE 2</b>	

**EXAMPLE:**  
Component Parts (Small #)  
Are Included When Ordering  
The Assembly (Large #).

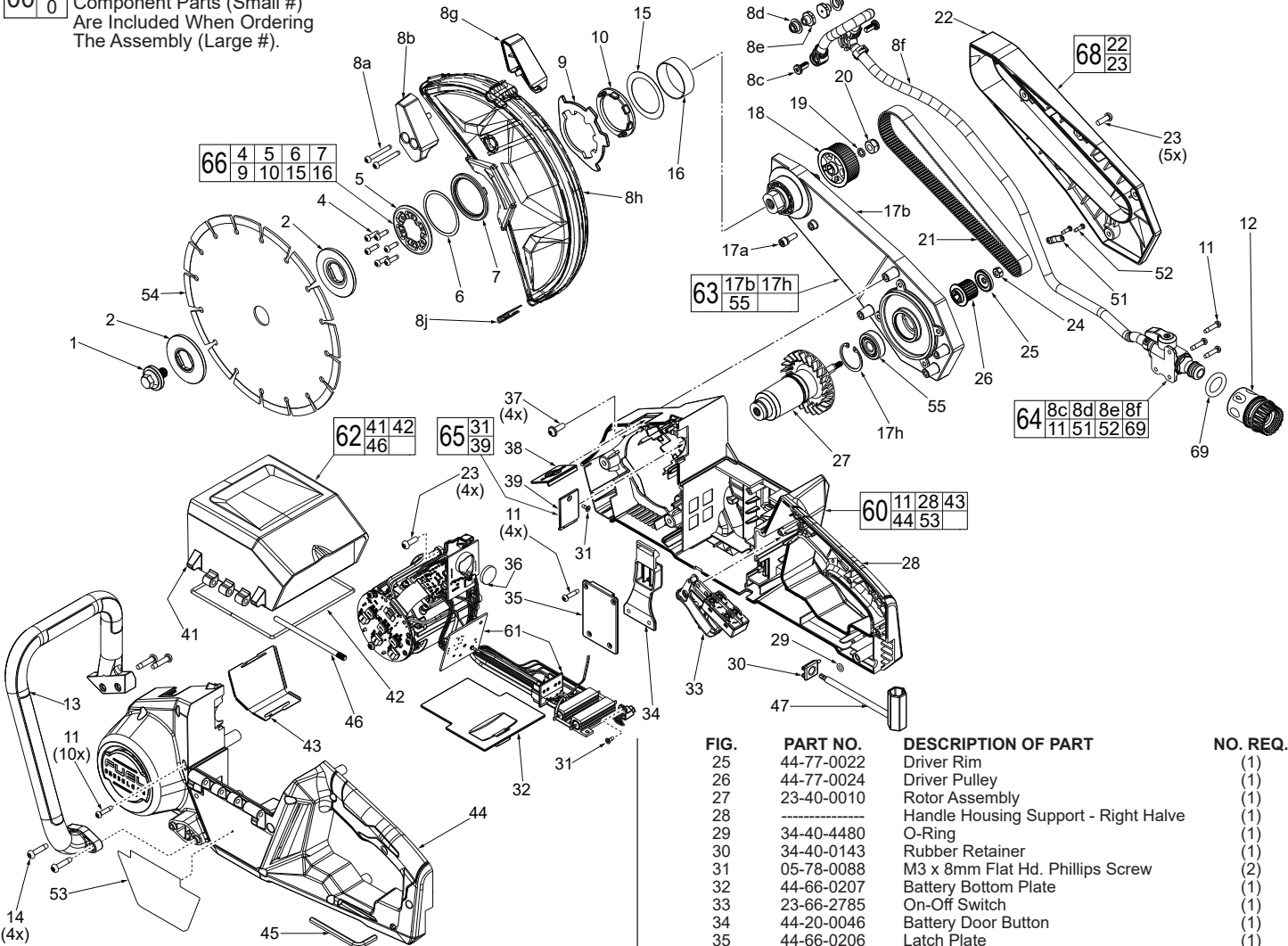
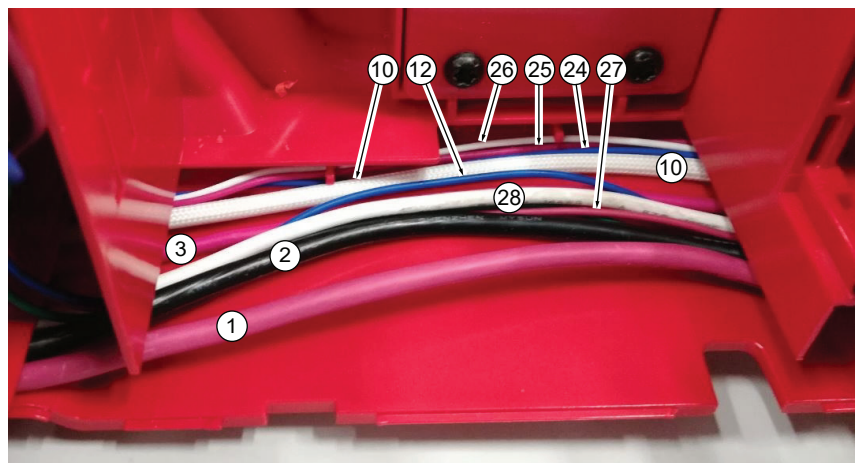
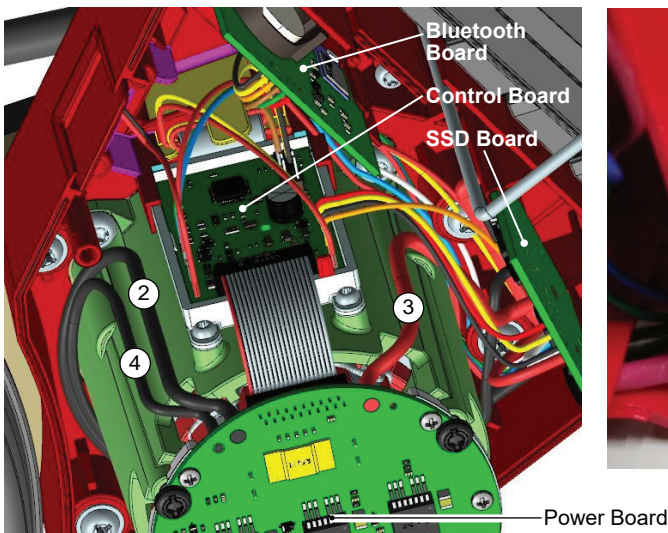
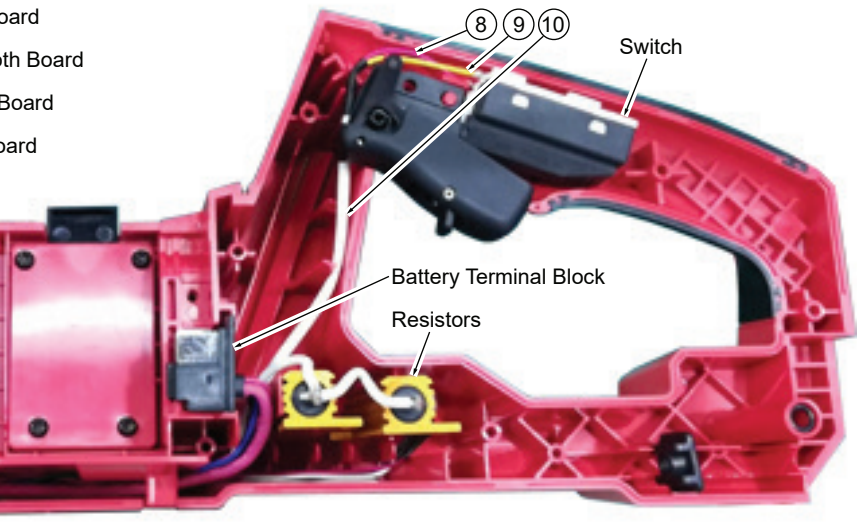
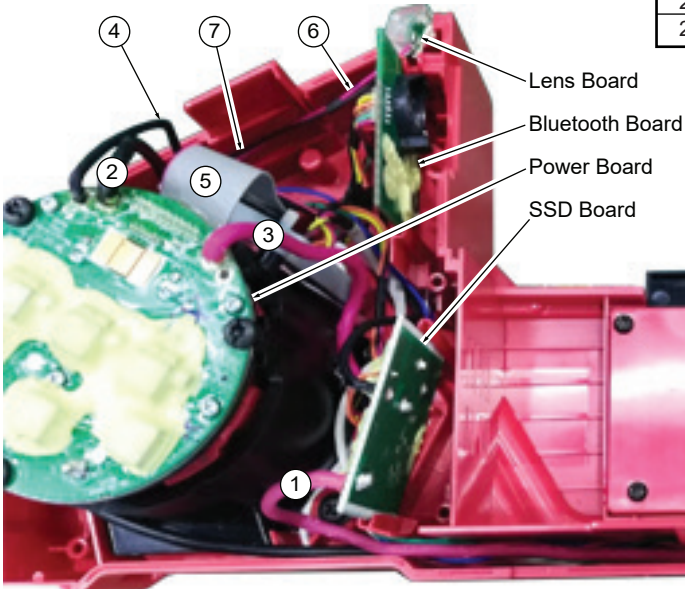
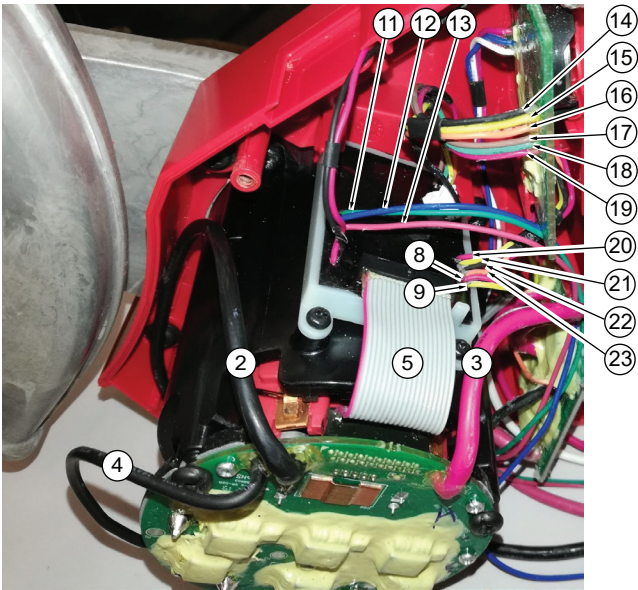

FIG.	PART NO.	DESCRIPTION OF PART	NO. REQ.
1	06-74-1090	M10 x 20mm Flange Head Bolt	(1)
2	49-05-0065	Blade Flange	(2)
4	05-78-5316	M4 x 14mm Pan Hd. Taptite T-20 Screw	(6)
5	-----	Output Plate	(1)
6	-----	Guard Pivot Shim 2	(1)
7	-----	Blade Pivot Gasket 1	(1)
8a	05-74-0023	M4 x 32mm Pan Hd. Taptite T-20 Screw	(2)
8b	28-20-0029	Guard Handle Halve - Left	(1)
8c	-----	Orifice Screw	(2)
8d	-----	Rubber Cap	(2)
8e	-----	Orifice	(2)
8f	-----	Valve Assembly	(1)
8g	31-50-0024	Guard Handle Halve - Right	(1)
8h	43-54-0013	Guard	(1)
8j	42-70-0014	Blade Guard Trim	(1)
9	-----	Guard Stop Plate	(1)
10	-----	Blade Pivot Gasket 2	(1)
11	06-82-0044	M4 x 18mm Pan Hd. ST T-20 Screw	(17)
12	43-33-0130	Quick Connect Fitting	(1)
13	43-62-0047	Bale Handle	(1)
14	06-82-0152	M5 x 22mm Pan Hd. ST T-25 Screw	(4)
15	-----	Guard Pivot Shim 1	(1)
16	-----	Delrin Spacer	(1)
17a	05-74-0029	M5 x 16mm Cap Hd. Hex Recess Screw	(1)
17b	-----	Arm with Bearings	(1)
17h	44-90-0048	Internal Snap Ring	(1)
18	28-95-0071	Output Pulley	(1)
19	45-88-0103	Washer	(1)
20	05-55-0025	LH Hex Nut	(1)
21	42-25-0002	Drive Belt	(1)
22	-----	Arm Cover	(1)
23	06-82-3065	M5 x 15mm Pan Hd. T-25 Machine Screw	(9)
24	05-55-0620	RH Hex Nut	(1)

FIG.	PART NO.	DESCRIPTION OF PART	NO. REQ.
25	44-77-0022	Driver Rim	(1)
26	44-77-0024	Driver Pulley	(1)
27	23-40-0010	Rotor Assembly	(1)
28	-----	Handle Housing Support - Right Halve	(1)
29	34-40-4480	O-Ring	(1)
30	34-40-0143	Rubber Retainer	(1)
31	05-78-0088	M3 x 8mm Flat Hd. Phillips Screw	(2)
32	44-66-0207	Battery Bottom Plate	(1)
33	23-66-2785	On-Off Switch	(1)
34	44-20-0046	Battery Door Button	(1)
35	44-66-0206	Latch Plate	(1)
36	-----	3V Coin Cell Battery (CR2032)	(1)
37	05-81-0060	M5 x 15mm Pan Hd. Phillips Machine Screw	(4)
38	44-66-0208	'Rapid Stop' Plate	(1)
39	-----	Coin Cell Battery Door	(1)
41	31-21-0027	Main Battery Door	(1)
42	45-06-0029	Gasket	(1)
43	44-66-0212	Skid Plate	(1)
44	-----	Handle Housing Cover - Left Halve	(1)
45	49-96-0021	Hex Key	(1)
46	44-60-0142	Battery Door Pin	(1)
47	49-96-0031	Hex/Torx Wrench	(1)
51	42-68-0016	Clip	(1)
52	05-81-0005	M3 x 11mm Pan Hd. Taptite T-10 Screw	(2)
53	12-20-0292	Service Nameplate	(1)
54	49-93-7025	9" Diamond Prem. Seg. Blade (Accessory)	(1)
54	49-94-9000	9" Cut Off Wheel (Accessory)	(1)
55	02-04-0067	Ball Bearing	(1)
60	31-44-0188	Handle Housing Kit	(1)
61	14-20-0181	Electronics Assembly	(1)
62	31-12-0031	Main Battery Door Kit	(1)
63	14-29-0044	Arm Assembly w/ Output Shaft & Bearings	(1)
64	43-76-0044	Valve/Hose Assembly	(1)
65	31-15-0046	Coin Cell Cover Kit	(1)
66	43-54-0026	Plate/Gasket Kit	(1)
68	42-09-0015	Cover Kit	(1)
69	34-40-0166	O-Ring	(1)

## WIRING SPECIFICATIONS

Wire No.	Wire Color	Terminals, Connectors and End Wire Preparation
1	Red	Battery Terminal Block to SSD Board
2	Black	Battery Terminal Block to SSD Board
3	Red	Power Board to SSD Board
4	Black	Power Board to SSD Board
5	White	Ribbon Cable. Control Board to Power Board
6	Red	Control Board to Lens Board
7	Black	Control Board to Lens Board
8	Red	Switch to Control Board
9	Yellow	Switch to Control Board
10	White	Switch to Control Board
11	Green	Battery Terminal Block to Control Board
12	Blue	Battery Terminal Block to Control Board
13	Red	Battery Terminal Block to Control Board
14	Black	Blue Tooth Board to Control Board
15	Yellow	Blue Tooth Board to Control Board
16	Orange	Blue Tooth Board to Control Board
17	Brown	Blue Tooth Board to Control Board
18	Green	Blue Tooth Board to Control Board
19	Red	Blue Tooth Board to Control Board
20	Red	Control Board to SSD Board
21	Yellow	Control Board to SSD Board
22	Black	Control Board to SSD Board
23	Orange	Control Board to SSD Board
24	Blue	Cos BT Board to One Key Lens
25	White	Cos BT Board to One Key Lens
26	Red	Cos BT Board to One Key Lens
27	Red	Resistor to SSD Board
28	White	Resistor to SSD Board



## SCREW TORQUE SPECIFICATIONS

FIG.	PART NO.	DESCRIPTION OF FASTENER	WHERE USED	SEAT TORQUE	
				(KG/CM)	(IN/LBS)
1	06-74-1090	M10 x 20mm Flange Head Bolt	Blade/Blade Flange	30±3	26±2
4	05-78-5316	M4 x 14mm Pan Hd. Taptite T-20 Screw	Output Plate	25±3	22±2
8a	05-24-0023	M4 x 32mm Pan Hd. Taptite T-20 Screw	Guard Handle Halve-Left	15±2	13±2
8c	-----	Orifice Screw	Guard/Hose Assembly	20±2	17±2
11	06-82-0044	M4 x 18mm Pan Hd. ST T-20 Screw	Handle Hsg. Cover, Latch Plate, Valve Assy.	14±1	12±1
14	06-82-0152	M5 x 22mm Pan Hd. ST T-25 Screw	Bale Handle	24±2	21±2
17a	05-74-0029	M5 x 16mm Cap Head Hex Recess Screw	Arm Assembly	25±2	22±2
20	05-55-0025	LH M8 Hex Nut	Spindle of Arm Assembly	300±25	260±22
23	06-82-3065	M5 x 15mm Pan Hd. T-25 Machine Screw	Motor Housing of Electronics Assembly	35±3	30±3
24	05-55-0620	RH M5 Hex Nut	Armature Spindle through Arm Assembly	100±5	87±4
31	05-78-0088	M3 x 8mm Flat Hd. Phillips Screw	Coin Cell Cover	4.5±1	4±1
37	05-81-0060	M5 x 15mm Pan Hd. Phillips Machine Screw	Handle Hsg. Support, Arm Assembly	28±2	24±2
52	05-81-0005	M3 x 11mm Pan Hd. Taptite T-10 Screw	Clip for Hose/Valve Assembly	6±1	5±1

**RED fasteners listed in this chart indicate critical torques**