



# SERVICE PARTS LIST

**BULLETIN NO.**  
**54-40-2810**

## MOTOR ARM/LOWER GUARD ASSEMBLIES

SPECIFY CATALOG NO. AND SERIAL NO. WHEN ORDERING PARTS		REVISED BULLETIN	DATE
<b>M18™ FUEL™ 12" MITER SAW with One-Key™</b>			Dec. 2020
CATALOG NO.	<b>2739-20</b>	SERIAL NUMBER	<b>K18A</b>
WIRING INSTRUCTION			

**EXAMPLE:**  
Component Parts (Small #) Are Included  
When Ordering The Assembly (Large #).

SERVICE TABLE OF CONTENTS	
Page 1	Motor Arm/Lower Guard Assemblies
Page 2	Motor/Handle/Electronics Assemblies
Page 3	Bevel Arm/Slide Assemblies
Page 4	Table Assembly
Page 5	Base Assembly
Page 6	Lubrication
Page 7 & 8	Wiring Diagram

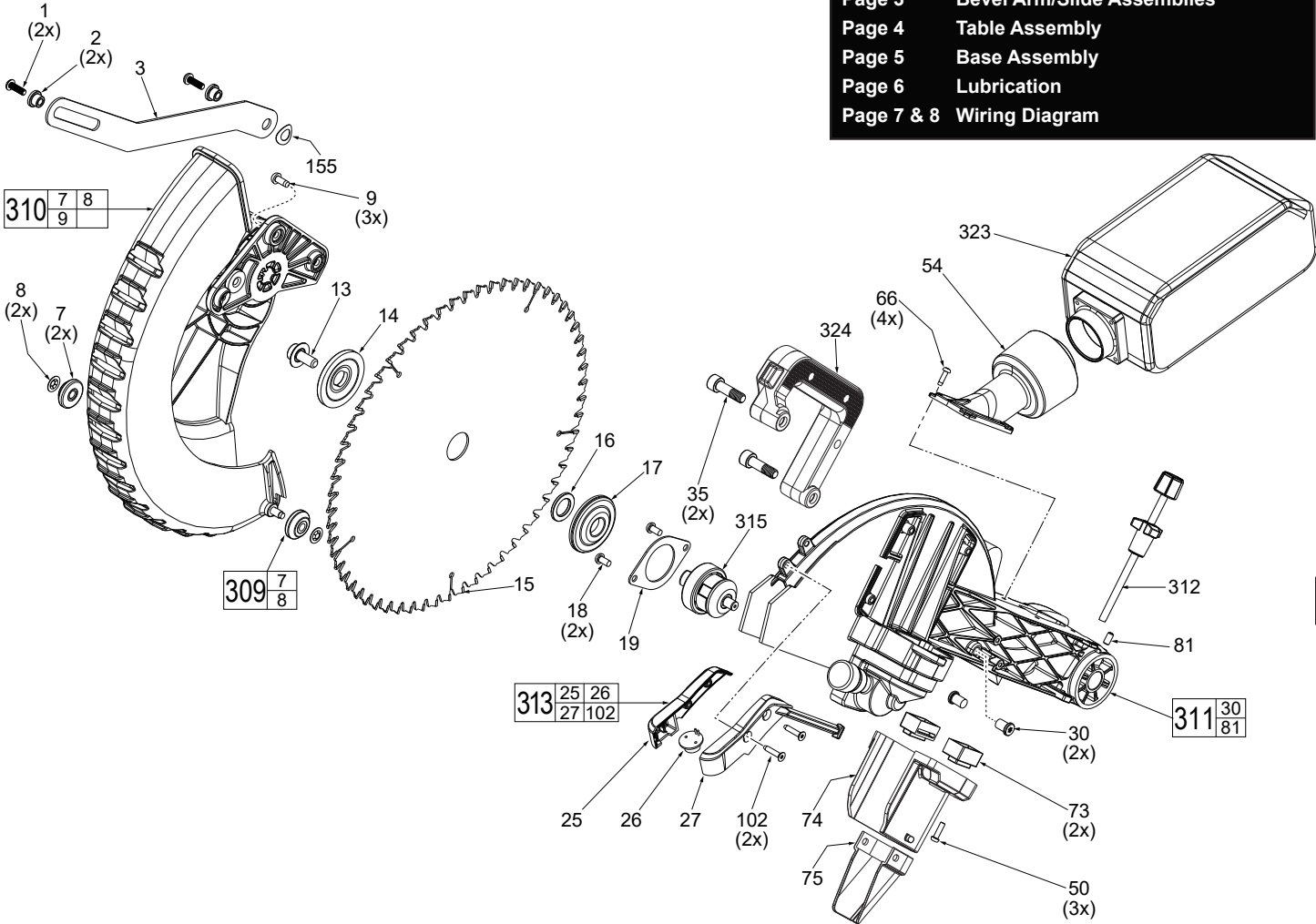

FIG.	PART NO.	DESCRIPTION OF PART	NO. REQ.
1	05-81-0817	M5 x 20mm Pan Hd. T-25 Mach. Scr.	(1)
2	42-40-0936	Lower Guard Linkage Bushing	(1)
3	44-14-0021	Guard Link Arm	(1)
7	-----	Lower Guard Roller	(2)
8	-----	Lower Guard Retaining Ring	(2)
9	05-74-0195	M5 x 10mm Pan Hd. T-25 Mach. Screw	(3)
13	45-04-0410	6mm Hex Blade Screw, LH	(1)
14	43-34-0016	Outer Blade Flange	(1)
15	-----	12" Saw Blade	(1)
16	45-36-2026	Blade Spacer	(1)
17	43-34-0017	Inner Blade Flange	(1)
18	05-81-0007	M5 x 12mm Pan Hd. T-25 Mach. Scr.	(2)
19	44-66-1071	Bearing Retaining Plate	(1)
25	-----	Shadow Line Housing-Left	(1)
26	-----	Shadow Line Optic	(1)
27	-----	Shadow Line Housing-Right	(1)
30	43-56-0810	M8 x 11mm T-25 Blade Deflector	(2)
35	05-81-0006	Cap Hd. Hex Socket Machine Screw	(2)
50	05-88-1210	M4 x 14mm Pan Hd. T-20 Mach. Scr.	(3)
54	31-15-0276	Dust Chute Exhaust	(1)
66	06-82-0225	M4 x 12mm Pan Hd. T-20 Mach. Scr.	(4)
73	44-06-0107	Cover Block	(2)
74	42-38-0007	Lower Dust Chute	(1)
75	42-38-0285	Dust Boot	(1)

FIG.	PART NO.	DESCRIPTION OF PART	NO. REQ.
81	06-83-0985	Set Screw	(1)
102	06-82-0235	M4 x 20mm Flat Hd. ST T-20 Screw	(2)
155	45-88-7104	Wave Washer	(1)
309	14-46-2489	Guard Roller Kit	(1)
310	14-32-0161	Lower Guard Assembly	(1)
311	14-38-0546	Motor Arm Assembly w/ Needle Bearing	(1)
312	14-46-2490	Dado Screw Assembly	(1)
313	14-46-0101	Shadow Line Kit	(1)
315	38-50-7031	Spindle Assembly	(1)
323	42-16-0241	Dust Bag Assembly	(1)
324	31-44-2780	Carrying Handle Kit	(1)

CRITICAL SCREW TORQUE SPECIFICATIONS				
FIG.	PART NO.	WHERE USED	SEAT TORQUE	
			(KG/CM)	(IN/LBS)
18	06-81-0007	Brg. Retaining Plate	45-50	39-43
102	06-82-0235	Shadow Line Hsg.	8-10	7-8



# SERVICE PARTS LIST

**BULLETIN NO.**  
**54-40-2810**

**MOTOR/ELECTRONICS/ HANDLE ASSEMBLIES**

SPECIFY CATALOG NO. AND SERIAL NO. WHEN ORDERING PARTS		REVISED BULLETIN	DATE
<b>M18™ FUEL™ 12" MITER SAW with One-Key™</b>			Nov. 2019
CATALOG NO.	<b>2739-20</b>	SERIAL NUMBER	<b>K18A</b>
WIRING INSTRUCTION			

**EXAMPLE:**  
Component Parts (Small #)  
Are Included When Ordering  
The Assembly (Large #).

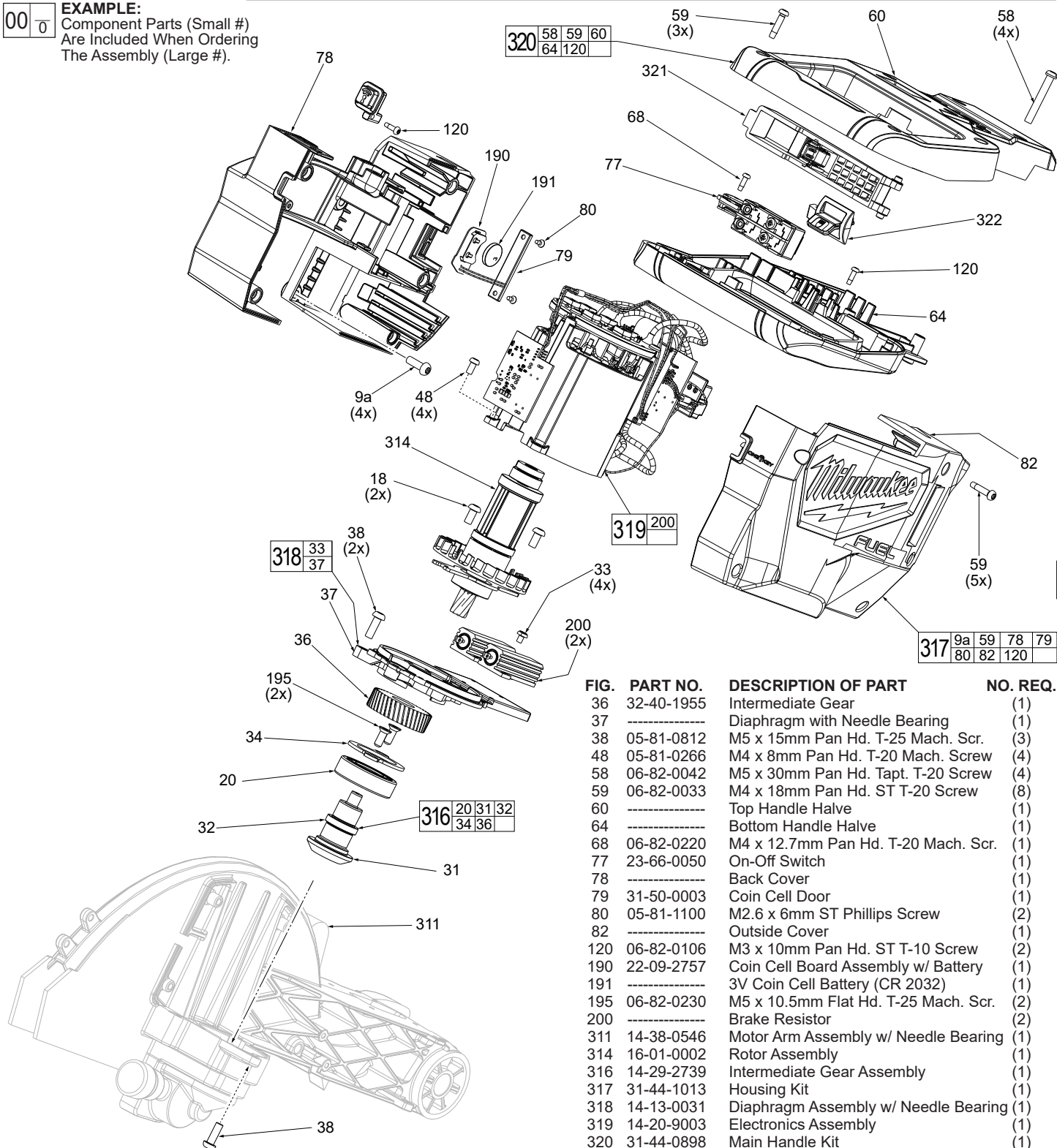

FIG.	PART NO.	DESCRIPTION OF PART	NO. REQ.
9a	05-81-0418	M5 x 12mm Pan Hd. T-25 Mach. Scr.	(4)
18	05-81-0007	M5 x 12mm Pan Hd. T-25 Mach. Scr.	(2)
20	02-04-1807	Ball Bearing	(1)
31	-----	Bevel Pinion	(1)
32	36-66-0585	Intermediate Shaft	(1)
33	05-81-0008	M3 x 5mm Machine Screw	(4)
34	44-66-7025	Intermediate Shaft Plate	(1)

FIG.	PART NO.	DESCRIPTION OF PART	NO. REQ.
36	32-40-1955	Intermediate Gear	(1)
37	-----	Diaphragm with Needle Bearing	(1)
38	05-81-0812	M5 x 15mm Pan Hd. T-25 Mach. Scr.	(3)
48	05-81-0266	M4 x 8mm Pan Hd. T-20 Mach. Screw	(4)
58	06-82-0042	M5 x 30mm Pan Hd. Tapt. T-20 Screw	(4)
59	06-82-0033	M4 x 18mm Pan Hd. ST T-20 Screw	(8)
60	-----	Top Handle Halve	(1)
64	-----	Bottom Handle Halve	(1)
68	06-82-0220	M4 x 12.7mm Pan Hd. T-20 Mach. Scr.	(1)
77	23-66-0050	On-Off Switch	(1)
78	-----	Back Cover	(1)
79	31-50-0003	Coin Cell Door	(1)
80	05-81-1100	M2.6 x 6mm ST Phillips Screw	(2)
82	-----	Outside Cover	(1)
120	06-82-0106	M3 x 15mm Pan Hd. ST T-10 Screw	(2)
190	22-09-2757	Coin Cell Board Assembly w/ Battery	(1)
191	-----	3V Coin Cell Battery (CR 2032)	(1)
195	06-82-0230	M5 x 10.5mm Flat Hd. T-25 Mach. Scr.	(2)
200	-----	Brake Resistor	(2)
311	14-38-0546	Motor Arm Assembly w/ Needle Bearing	(1)
314	16-01-0002	Rotor Assembly	(1)
316	14-29-2739	Intermediate Gear Assembly	(1)
317	31-44-1013	Housing Kit	(1)
318	14-13-0031	Diaphragm Assembly w/ Needle Bearing	(1)
319	14-20-9003	Electronics Assembly	(1)
320	31-44-0898	Main Handle Kit	(1)
321	31-92-0201	Trigger Paddle Assembly	(1)
322	31-01-0002	LED Button Assembly	(1)

CRITICAL SCREW TORQUE SPECIFICATIONS				
FIG.	PART NO.	WHERE USED	SEAT TORQUE	
			(KG/CM)	(IN/LBS)
18	06-81-0007	Brg. Retaining Plate	30-40	26-34



# SERVICE PARTS LIST

**BEVEL ARM / RAIL ASSEMBLIES**

**BULLETIN NO.**

**54-40-2810**

SPECIFY CATALOG NO. AND SERIAL NO. WHEN ORDERING PARTS		REVISED BULLETIN	DATE
<b>M18™ FUEL™ 12" MITER SAW with One-Key™</b>			Nov. 2019
CATALOG NO.	<b>2739-20</b>	SERIAL NUMBER	<b>K18A</b>
WIRING INSTRUCTION			

**EXAMPLE:**  
Component Parts (Small #) Are Included When Ordering The Assembly (Large #).

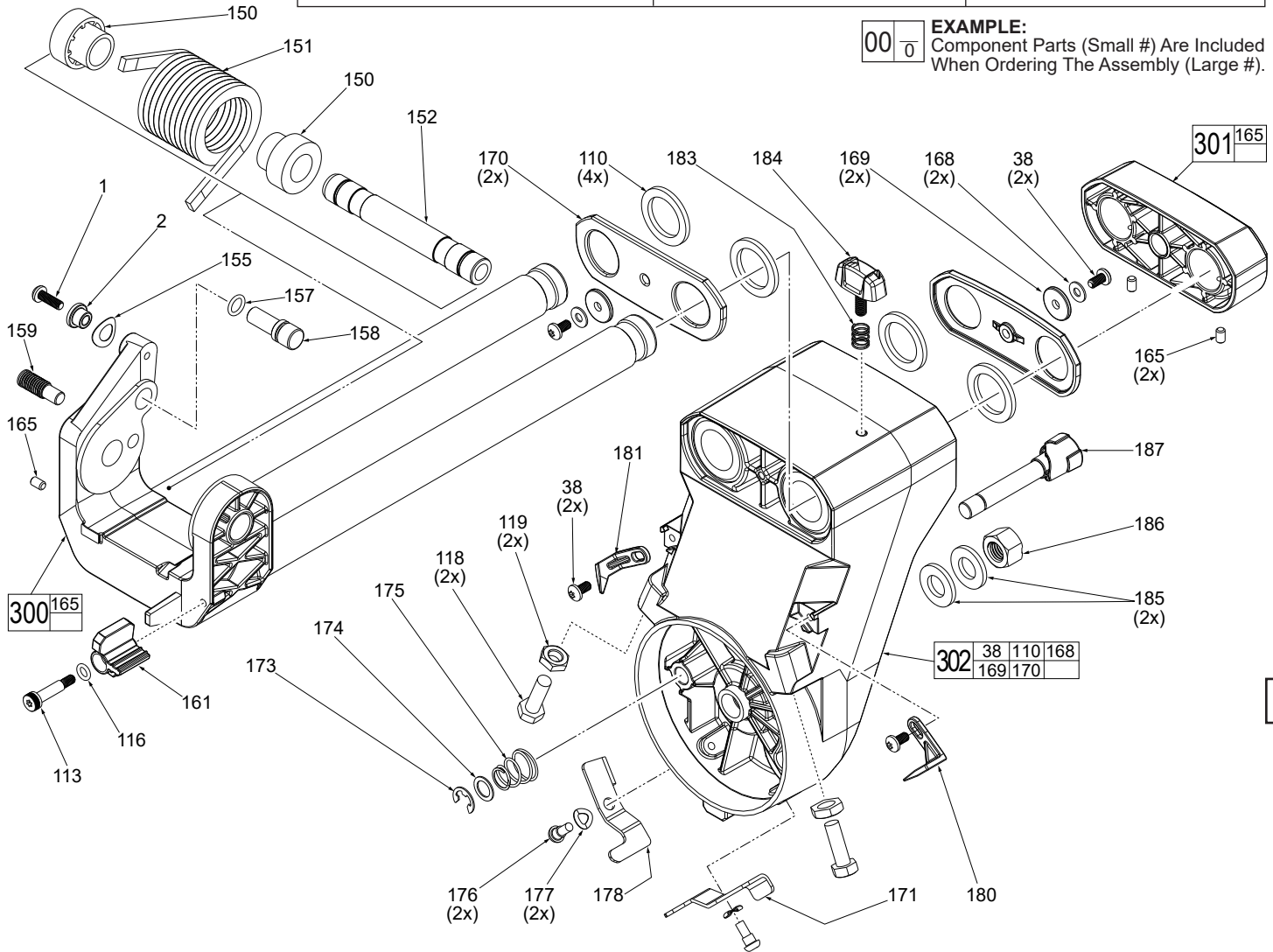

**3**

FIG.	PART NO.	DESCRIPTION OF PART	NO. REQ.
1	05-81-0817	M5 x 20mm Pan Hd. T-25 Mach. Screw	(1)
2	42-40-0936	Lower Guard Linkage Bushing	(1)
38	05-81-0007	M5 x 15mm Pan Hd. T-25 Mach. Scr.	(4)
110	45-06-0023	Felt Seal	(4)
113	05-89-0102	M5 x 20mm T-25 Shoulder Screw	(1)
116	34-40-0056	O-Ring	(1)
118	06-14-0034	M8 x 25mm Hex Hd. Machine Screw	(2)
119	05-55-0050	M8 Hex Jam Nut	(2)
150	42-40-0192	Pivot Spring Bushing	(2)
151	40-50-8899	Axle Spring	(1)
152	42-12-0220	Bevel Axle	(1)
155	45-88-7104	Wave Washer	(1)
157	34-40-0251	O-Ring	(1)
158	44-60-0003	Lock Down Pin	(1)
159	05-89-0521	Stop Screw	(1)
161	45-52-2055	Depth Stop	(1)
165	06-83-0011	M5 x 10mm Set Screw	(3)
168	45-88-1731	Flat Washer	(2)
169	45-88-1701	Buffer Pad	(2)
170	42-92-0006	Bearing Cover	(2)
171	44-10-0002	45 Degree Flip-Right	(1)
173	34-60-0087	External Retaining Ring	(1)
174	45-88-2209	Washer	(1)
175	40-50-0143	Conical Spring	(1)
176	05-89-0533	Shoulder Screw	(2)

FIG.	PART NO.	DESCRIPTION OF PART	NO. REQ.
177	45-88-8691	Wave Washer	(2)
178	44-10-0003	45 Degree Flip-Left	(1)
180	44-72-0032	Bevel Pointer-Right	(1)
181	44-72-0031	Bevel Pointer-Left	(1)
183	40-50-1017	Spring	(1)
184	44-20-0565	Lock Knob	(1)
185	45-88-1767	Washer	(2)
186	05-59-0145	M12 Hex Nut	(1)
187	44-60-0066	Bevel Stop Pin	(1)
300	43-70-0076	Arm Hinge/Slide Rail Assembly	(1)
301	42-68-1000	Rail Clamp Assembly	(1)
302	14-29-0063	Bevel Arm Assembly	(1)



# SERVICE PARTS LIST

**BULLETIN NO.**  
**54-40-2810**

## TABLE ASSEMBLY

SPECIFY CATALOG NO. AND SERIAL NO. WHEN ORDERING PARTS		REVISED BULLETIN	DATE
<b>M18™ FUEL™ 12" MITER SAW with One-Key™</b>			Nov. 2019
CATALOG NO.	<b>2739-20</b>	SERIAL NUMBER	<b>K18A</b>
WIRING INSTRUCTION			

### CRITICAL SCREW TORQUE SPECIFICATIONS

FIG.	PART NO.	WHERE USED	SEAT TORQUE	
			(KG/CM)	(IN/LBS)
91	05-74-1015	Detent Spring	60-70	50-60
122	45-58-0135	Table Assembly	250-300	217-260

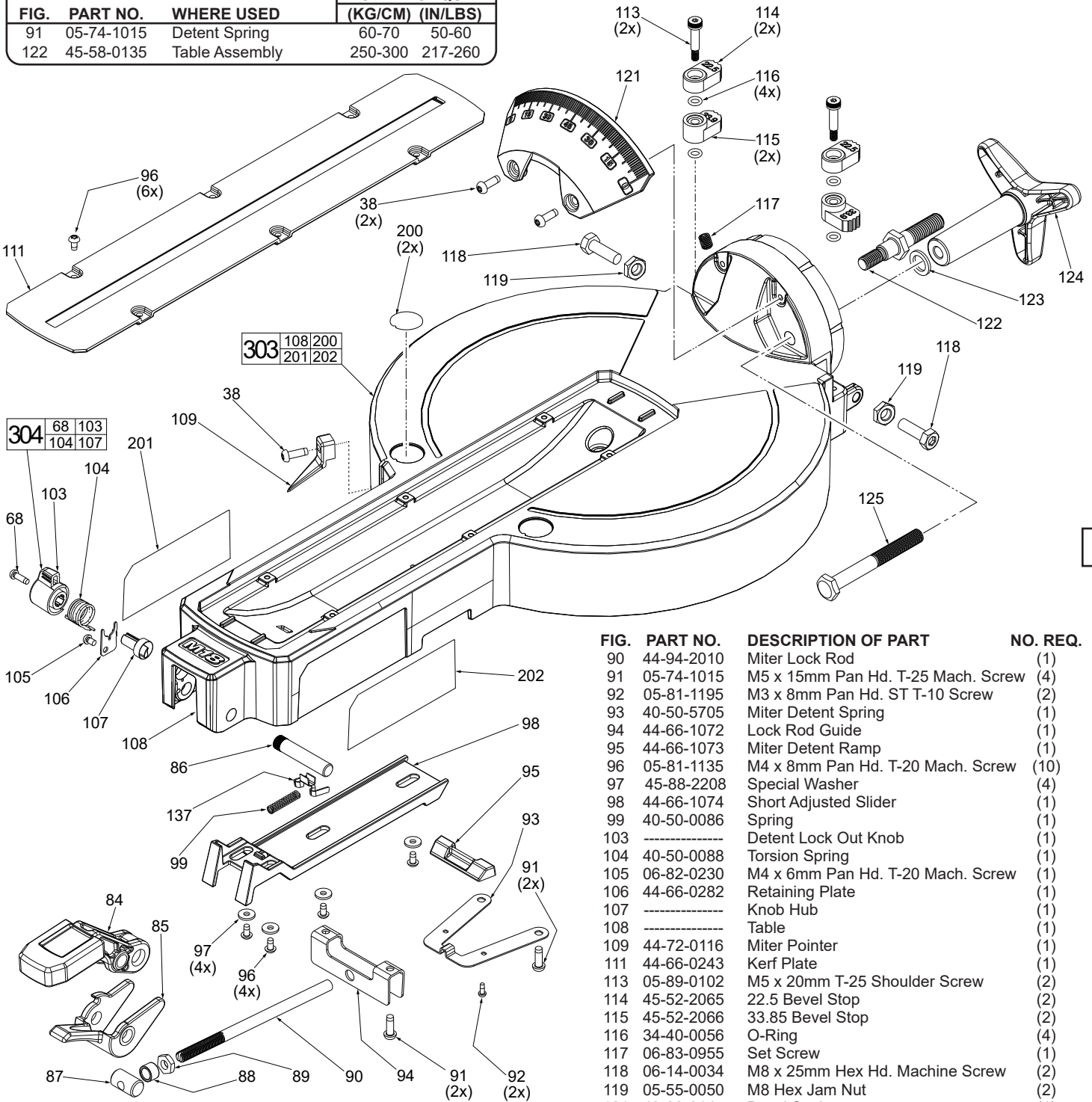

FIG.	PART NO.	DESCRIPTION OF PART	NO. REQ.
90	44-94-2010	Miter Lock Rod	(1)
91	05-74-1015	M5 x 15mm Pan Hd. T-25 Mach. Screw	(4)
92	05-81-1195	M3 x 8mm Pan Hd. ST T-10 Screw	(2)
93	40-50-5705	Miter Detent Spring	(1)
94	44-66-1072	Lock Rod Guide	(1)
95	44-66-1073	Miter Detent Ramp	(1)
96	05-81-1135	M4 x 8mm Pan Hd. T-20 Mach. Screw	(10)
97	45-88-2208	Special Washer	(4)
98	44-66-1074	Short Adjusted Slider	(1)
99	40-50-0086	Spring	(1)
103	-----	Detent Lock Out Knob	(1)
104	40-50-0088	Torsion Spring	(1)
105	06-82-0230	M4 x 6mm Pan Hd. T-20 Mach. Screw	(1)
106	44-66-0282	Retaining Plate	(1)
107	-----	Knob Hub	(1)
108	-----	Table	(1)
109	44-72-0116	Miter Pointer	(1)
111	44-66-0243	Kerf Plate	(1)
113	05-89-0102	M5 x 20mm T-25 Shoulder Screw	(2)
114	45-52-2065	22.5 Bevel Stop	(2)
115	45-52-2066	33.85 Bevel Stop	(2)
116	34-40-0056	O-Ring	(4)
117	06-83-0955	Set Screw	(1)
118	06-14-0034	M8 x 25mm Hex Hd. Machine Screw	(2)
119	05-55-0050	M8 Hex Jam Nut	(2)
121	43-82-0147	Bevel Scale	(1)
122	45-58-0135	Bevel Stud	(1)
123	45-88-1732	Flat Washer	(1)
124	43-98-0088	Bevel Knob	(1)
125	06-14-0032	M10 x 90mm Hex Hd. Machine Screw	(1)
137	44-86-0021	Miter Detent Spring Board	(1)
200	10-20-2239	'No Hands' Warning Label	(2)
201	10-20-1400	'Miter Detent Override' Warning Label-Left	(1)
202	10-20-1404	'Slide Away' Warning Label-Right	(1)
303	28-06-1038	Table Assembly with Labels	(1)
304	44-20-0238	Miter Override Lock Assembly	(1)

FIG.	PART NO.	DESCRIPTION OF PART	NO. REQ.
38	05-81-0007	M5 x 15mm Pan Hd. T-25 Mach. Scr.	(3)
68	06-82-0220	M4 x 12.7mm Pan Hd. T-20 Mach. Scr.	(1)
84	43-62-0146	Miter Lock Handle	(1)
85	45-72-0100	Detent Release Trigger	(1)
86	44-60-0053	Handle Pivot Pin	(1)
87	44-60-0063	Lock Rod Pivot Nut	(1)
88	45-22-0167	Miter Lock Sleeve	(1)
89	05-59-0160	Hex Nut	(1)



# SERVICE PARTS LIST

**BASE ASSEMBLY**

**BULLETIN NO.**

**54-40-2810**

SPECIFY CATALOG NO. AND SERIAL NO. WHEN ORDERING PARTS		REVISED BULLETIN	DATE
<b>M18™ FUEL™ 12" MITER SAW</b>			Nov. 2019
CATALOG NO.	<b>2739-20</b>	SERIAL NUMBER	<b>K18A</b>
		WIRING INSTRUCTION	

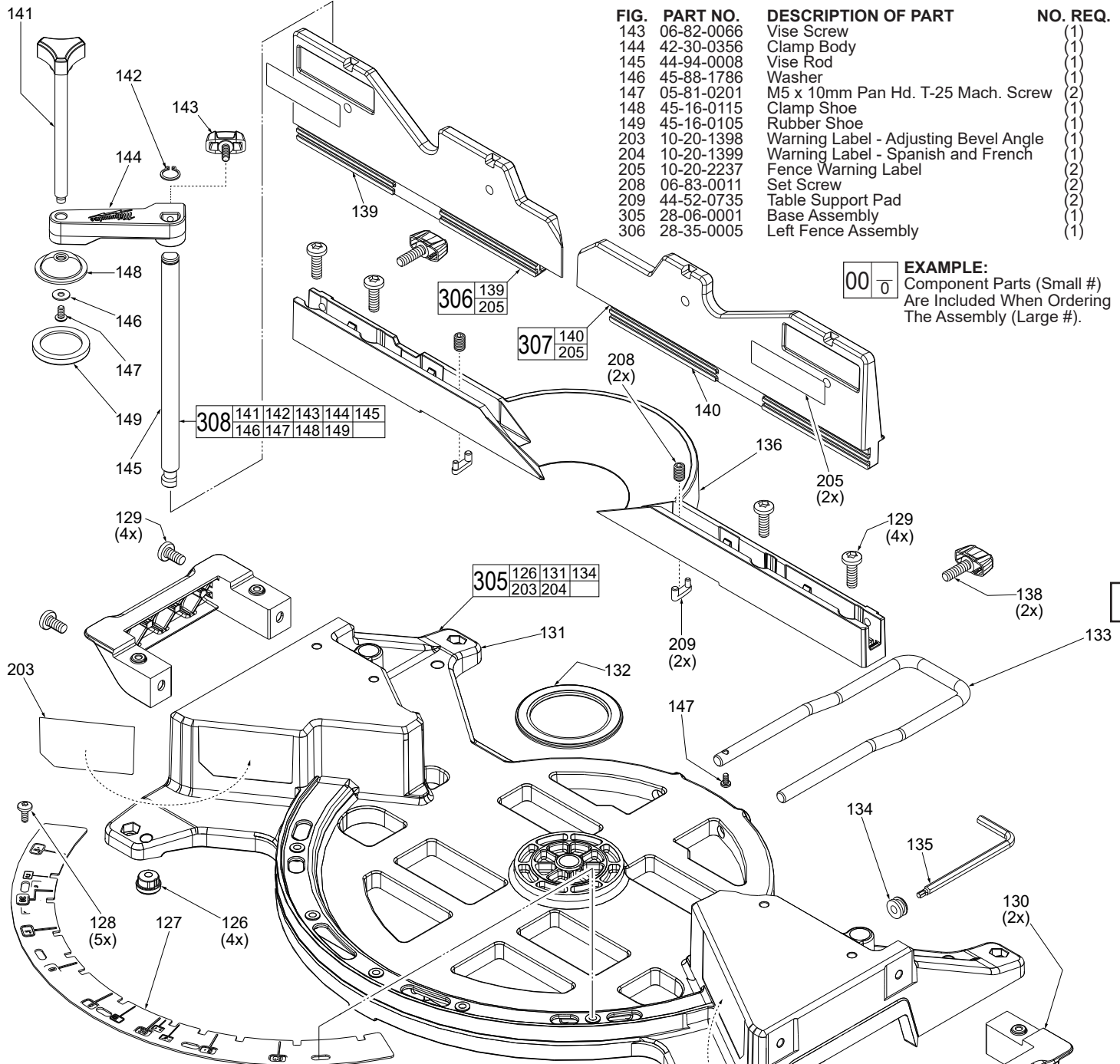

FIG.	PART NO.	DESCRIPTION OF PART	NO. REQ.
143	06-82-0066	Vise Screw	(1)
144	42-30-0356	Clamp Body	(1)
145	44-94-0008	Vise Rod	(1)
146	45-88-1786	Washer	(1)
147	05-81-0201	M5 x 10mm Pan Hd. T-25 Mach. Screw	(2)
148	45-16-0115	Clamp Shoe	(1)
149	45-16-0105	Rubber Shoe	(1)
203	10-20-1398	Warning Label - Adjusting Bevel Angle	(1)
204	10-20-1399	Warning Label - Spanish and French	(1)
205	10-20-2237	Fence Warning Label	(2)
208	06-83-0011	Set Screw	(2)
209	44-52-0735	Table Support Pad	(2)
305	28-06-0001	Base Assembly	(1)
306	28-35-0005	Left Fence Assembly	(1)

**EXAMPLE:**  
Component Parts (Small #)  
Are Included When Ordering  
The Assembly (Large #).

FIG.	PART NO.	DESCRIPTION OF PART	NO. REQ.
100	45-08-0471	Table Bolt	(1)
101	40-50-8621	Belleville Spring Washer	(4)
126	44-34-0017	Miter Base Foot	(1)
127	42-92-1157	Detent Plate Scale	(1)
128	05-89-0533	M5 x 13mm Pan Hd. T-25 Shoulder Scr.	(5)
129	05-81-0149	M8 x 25mm Pan Hd. T-30 Mach. Screw	(8)
130	31-44-0899	Base Handle	(2)
131	-----	Base	(1)
132	02-80-0060	Thrust Bearing	(1)
133	44-94-0086	Kick Stand	(1)
134	22-90-0185	Wrench Grommet	(1)
135	49-96-0185	Wrench	(1)
136	28-35-0127	Fixed Fence	(1)
138	43-98-0041	Fence Lock Knob	(2)
139	-----	Left Sliding Fence	(1)
140	-----	Right Sliding Fence	(1)
141	43-98-0043	Vise Knob	(1)
142	34-60-0088	Retaining Ring	(1)

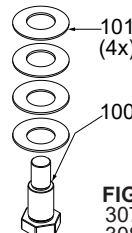

FIG.	PART NO.	DESCRIPTION OF PART	NO. REQ.
307	28-35-0007	Right Fence Assembly	(1)
308	42-38-0087	Material Clamp Assembly	(1)

CRITICAL SCREW TORQUE SPECIFICATIONS				
FIG.	PART NO.	WHERE USED	SEAT TORQUE	
			(KG/CM)	(IN/LBS)
100	45-08-0471	Base	600-640	520-555
128	05-89-0533	Detent Plate Scale	80-100	69-86

## LUBRICATION NOTES:

### Type 'Y' Grease

No. 49-08-5270, 6oz. tube

When servicing the gears or the Gear Case, 90-95% of the old grease must be removed prior to new grease being added. Clean gear assemblies with a clean, dry cloth.

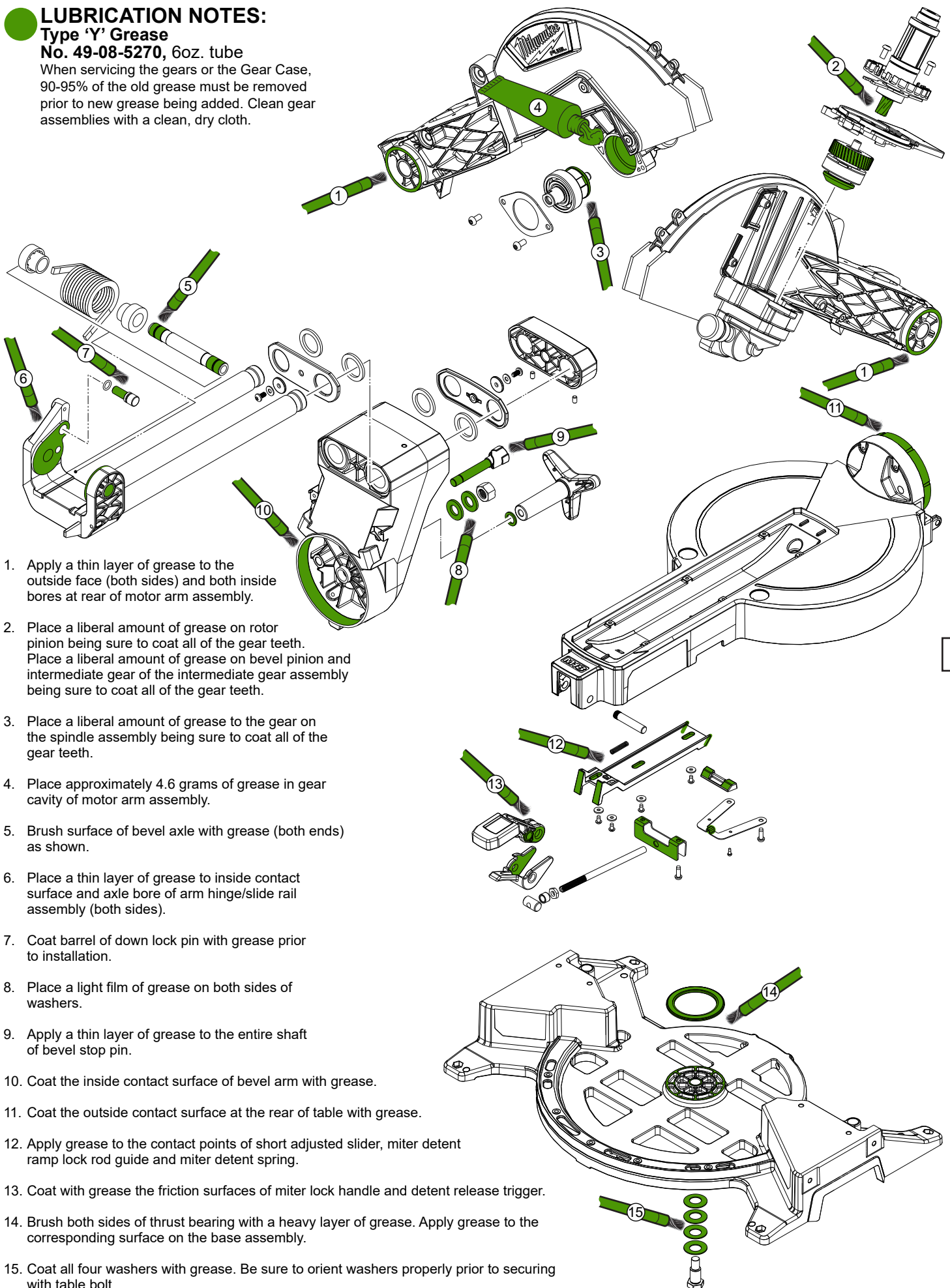

1. Apply a thin layer of grease to the outside face (both sides) and both inside bores at rear of motor arm assembly.
2. Place a liberal amount of grease on rotor pinion being sure to coat all of the gear teeth. Place a liberal amount of grease on bevel pinion and intermediate gear of the intermediate gear assembly being sure to coat all of the gear teeth.
3. Place a liberal amount of grease to the gear on the spindle assembly being sure to coat all of the gear teeth.
4. Place approximately 4.6 grams of grease in gear cavity of motor arm assembly.
5. Brush surface of bevel axle with grease (both ends) as shown.
6. Place a thin layer of grease to inside contact surface and axle bore of arm hinge/slide rail assembly (both sides).
7. Coat barrel of down lock pin with grease prior to installation.
8. Place a light film of grease on both sides of washers.
9. Apply a thin layer of grease to the entire shaft of bevel stop pin.
10. Coat the inside contact surface of bevel arm with grease.
11. Coat the outside contact surface at the rear of table with grease.
12. Apply grease to the contact points of short adjusted slider, miter detent ramp lock rod guide and miter detent spring.
13. Coat with grease the friction surfaces of miter lock handle and detent release trigger.
14. Brush both sides of thrust bearing with a heavy layer of grease. Apply grease to the corresponding surface on the base assembly.
15. Coat all four washers with grease. Be sure to orient washers properly prior to securing with table bolt.

As an aid to reassembly, take notice of wire routing and position in wire guides and traps while dismantling tool.

Be sure all electrical components are firmly and squarely seated in handle and housing cavities.

Be careful and avoid pinching wires between handle halves and in housings by tucking wires completely down in traps and channels when assembling.

Prior to installing the battery, check for proper functionality of switches, slides and buttons after housings and handles are secure.

Install battery and verify the proper operation of tool.

