



SERVICE PARTS LIST

BULLETIN NO.
54-38-2401

SPECIFY CATALOG NO. AND SERIAL NO. WHEN ORDERING PARTS		REVISED BULLETIN	DATE
M12 FUEL™ Tire Buffer			July 2021
CATALOG NO.	2409-20	STARTING SERIAL NO.	L81B
WIRING INSTRUCTION			

EXAMPLE:

00	0
----	---

 Component Parts (Small #) Are Included When Ordering The Assembly (Large #).

★ = Part number change from previous service parts list.

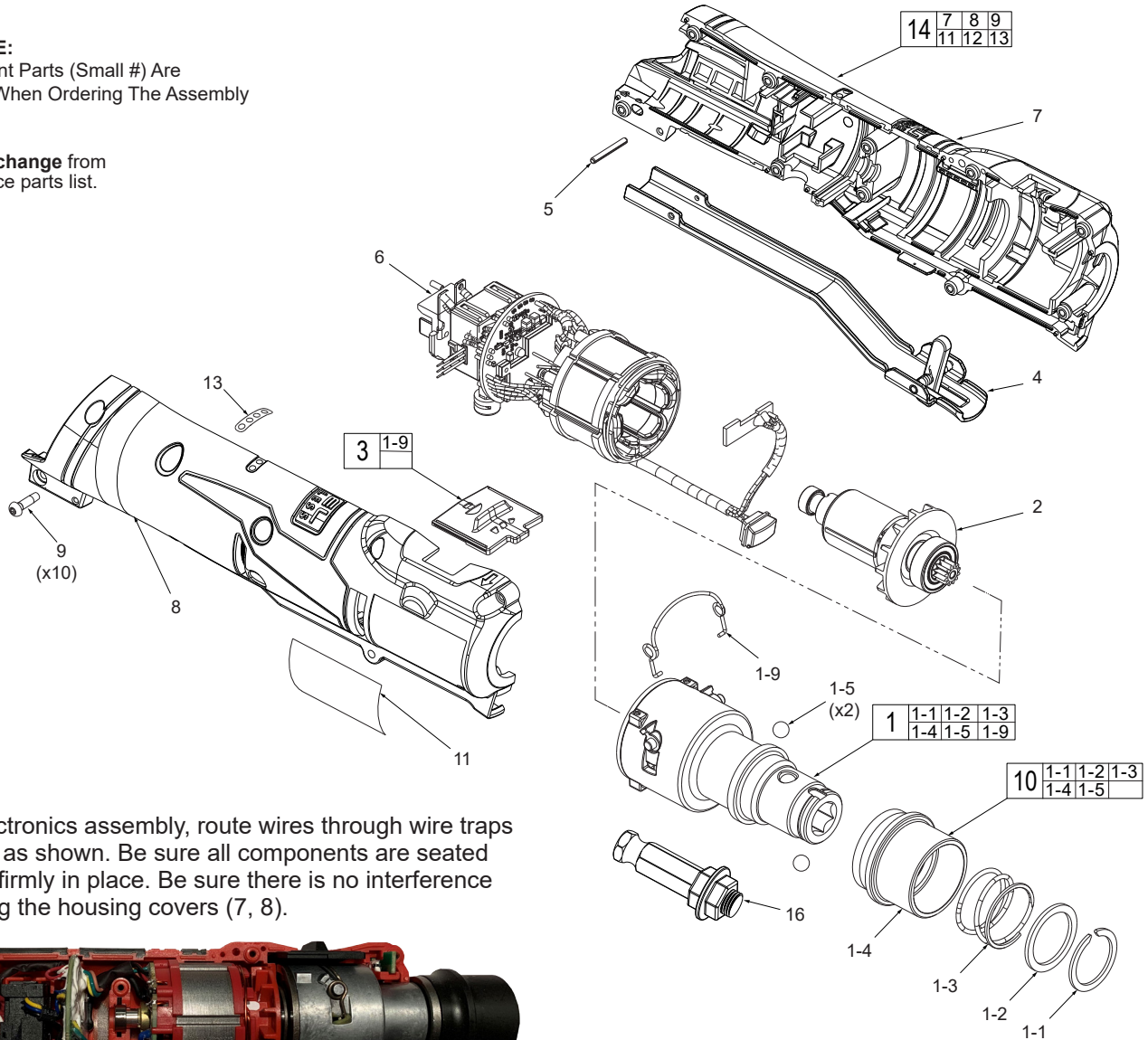

Install the electronics assembly, route wires through wire traps and channels as shown. Be sure all components are seated squarely and firmly in place. Be sure there is no interference when installing the housing covers (7, 8).

Wire Traps or Channels

FIG.	PART NO.	DESCRIPTION OF PART	NO. REQ.	FIG.	PART NO.	DESCRIPTION OF PART	NO. REQ.
1	14-30-2409	Gearbox Assembly w/ Sleeve	(1)	10	14-46-2409	Quick Disconnect Kit	(1)
1-1	34-60-0051	Retaining Ring	(1)	11	12-20-2487	Service Nameplate	(1)
1-2	44-90-0210	Washer	(1)	12	10-20-8001	Warning Label (Not Shown)	(1)
1-3	40-50-0364	Spring	(1)	13	10-20-4347	Gauge Label	(1)
1-4	42-76-0005	Sleeve	(1)	★ 14	14-34-2410	Housing Assembly	(1)
1-5	-----	Steel Ball	(2)	15	42-55-2425	Contractor Bag	(1)
1-9	44-10-0196	Change Lever	(1)	16	50-03-2409	Rasp Adapter	(1)
2	16-01-2409	Rotor Assembly	(1)				
3	45-24-0026	Speed Selector Assembly	(1)				
★ 4	44-10-2410	Paddle Assembly	(1)				
5	44-60-0575	Rivet Pin	(1)				
6	14-20-2409	PCBA Assembly	(1)				
7	-----	Housing Half-Support	(1)				
8	-----	Housing Half-Cover	(1)				
9	05-81-0005	M3 x 11mm Pan Hd. Taptite T-10 Screw	(10)				

SCREW TORQUE SPECIFICATIONS				
FIG.	PART NO.	WHERE USED	SEAT TORQUE	
			(KG/CM)	(IN/LBS)
9	05-81-0005	Housing Half Cover	6-8	4.0-6.0