

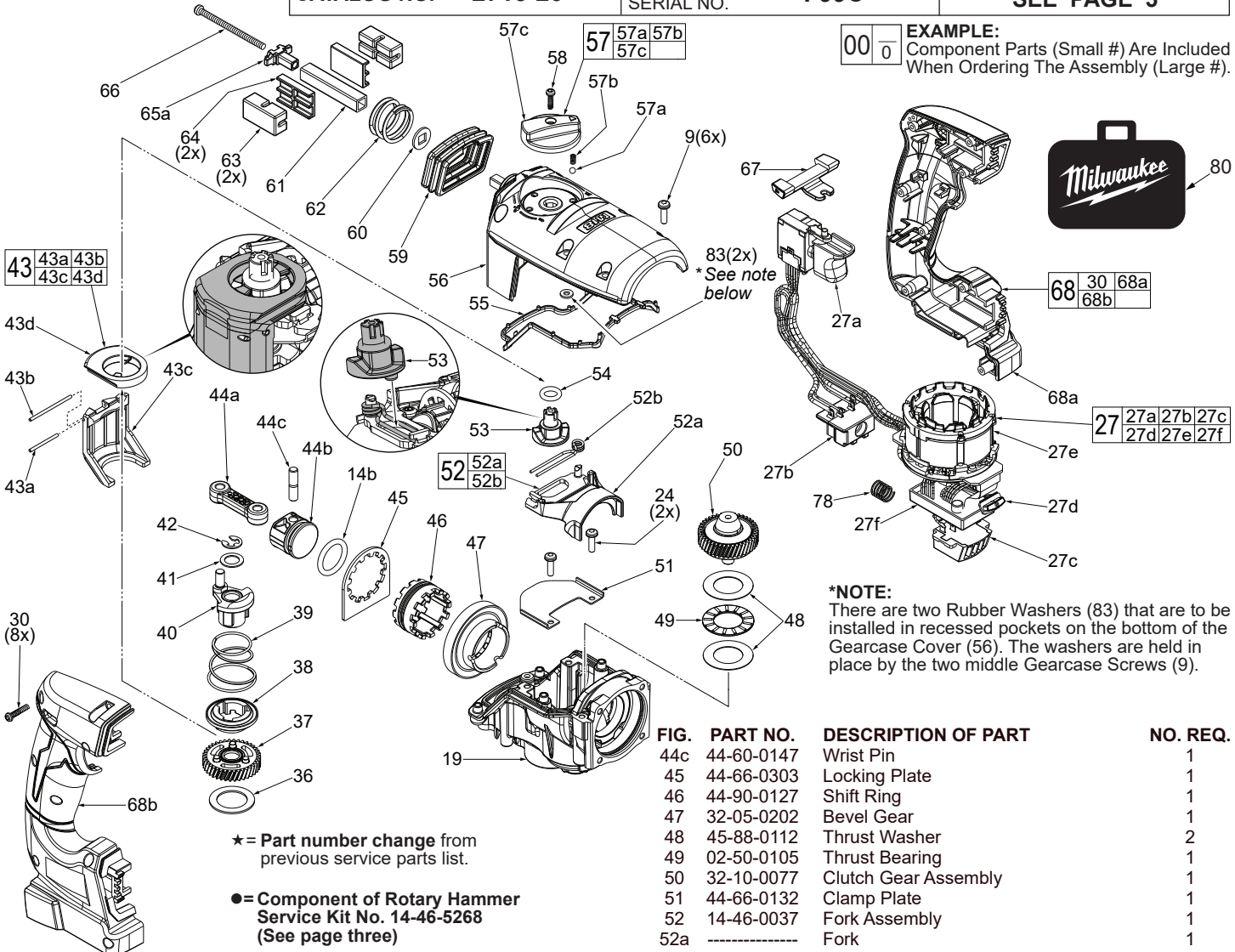

# SERVICE PARTS LIST

**BULLETIN NO.**  
**54-24-2702**

SPECIFY CATALOG NO. AND SERIAL NO. WHEN ORDERING PARTS		REVISED BULLETIN 54-24-2701	DATE Aug. 2020
<b>M18 FUEL™ 1-1/8" (3kg) Rotary Hammer</b>			
CATALOG NO.	2715-20	STARTING SERIAL NO.	F99C
		WIRING INSTRUCTION <b>SEE PAGE 5</b>	



**\*NOTE:**  
There are two Rubber Washers (83) that are to be installed in recessed pockets on the bottom of the Gearcase Cover (56). The washers are held in place by the two middle Gearcase Screws (9).

★ = Part number change from previous service parts list.  
● = Component of Rotary Hammer Service Kit No. 14-46-5268 (See page three)

FIG.	PART NO.	DESCRIPTION OF PART	NO. REQ.
9	06-75-2408	M4 x 17mm Pan Hd. Taptite T-20 w/Nylok	6
★ 19	34-40-0068	O-Ring (1 on Piston #42b, 1 on Ram #14a)	2
★ 19	14-29-0031	Gearbox Assembly	1
24	05-78-0105	M4 x 10mm Pan Hd. Taptite Screw (2 of 4)	2
27	14-20-2715	Electronics Assembly	1
27a	-----	On-Off Switch	1
27b	-----	Battery Connector Block	1
27c	-----	Connector Assembly	1
27d	-----	LED Assembly	1
27e	-----	Stator Assembly	1
27f	-----	PCB Assembly	1
30	06-82-2025	M3.5 x 16mm Pan Hd. Plast. T-10 (8 of 23)	23
36	45-88-0106	Washer	1
37	32-60-0112	Crank Gear Assembly with Needle Bearing	1
38	44-90-0152	Crank Shift Ring	1
39	40-50-0107	Crank Spring	1
40	14-09-0110	Crank Assembly	1
41	44-66-0122	Crank Shim	1
42	42-70-5268	● Retaining E-Ring	1
43	14-46-0117	Chisel Shifter Assembly	1
43a	-----	M2 x 27mm Dowel Pin	1
43b	-----	M2 x 40mm Dowel Pin	1
43c	-----	Chisel Bracket	1
43d	-----	Chisel Shift Driver	1
44a	44-94-0022	Connecting Rod	1
44b	44-62-0302	Piston	1

FIG.	PART NO.	DESCRIPTION OF PART	NO. REQ.
44c	44-60-0147	Wrist Pin	1
45	44-66-0303	Locking Plate	1
46	44-90-0127	Shift Ring	1
47	32-05-0202	Bevel Gear	1
48	45-88-0112	Thrust Washer	2
49	02-50-0105	Thrust Bearing	1
50	32-10-0077	Clutch Gear Assembly	1
51	44-66-0132	Clamp Plate	1
52	14-46-0037	Fork Assembly	1
52a	-----	Fork	1
52b	-----	Fork Spring	1
53	42-90-0022	Shifting Coupler	1
54	34-40-0093	● O-Ring	1
55	42-92-0053	● Gearcase Gasket (See page three)	1
56	28-20-0023	Gearcase Cover	1
57	44-10-0057	Selector Knob Assembly	1
57a	-----	Selector Ball	1
57b	-----	Selector Spring	1
57c	-----	Selector Knob	1
58	06-82-2025	M3.5 x 16mm Pan Hd. Plastite T-10 Screw	1
59	22-90-0132	Top Bellows	1
60	45-88-0153	Vibration Washer (1 each for top & bottom AVS)	2
61	44-20-0141	Top AVS Square Guide Pipe	1
62	40-50-0211	Top AVS Spring	1
63	42-38-0077	Vibration Bumper (2 each for top & bottom AVS)	4
64	42-38-0137	Bumper Holder (2 each for top & bottom AVS)	4
65a	44-66-0132	Retaining Plate	1
66	05-78-0012	M4 x 52mm Scr. (1 each for top & bottom AVS)	2
67	42-42-2715	Forward/Reverse Button	1
68	31-44-2725	Handle Assembly	1
68a	-----	Left Handle Halve	1
68b	-----	Right Handle Halve	1
78	40-50-1090	Compression Spring	1
80	42-55-2715	Carrying Case for 2715-20 Tool Only and 2715-22 Kit	1
80	42-55-0115	Carrying Case for 2715-22DE Tool with Dust Extractor	1
83	45-88-0014	● Rubber Washer	2

● = Component of Rotary Hammer  
Service Kit No. 14-46-5268

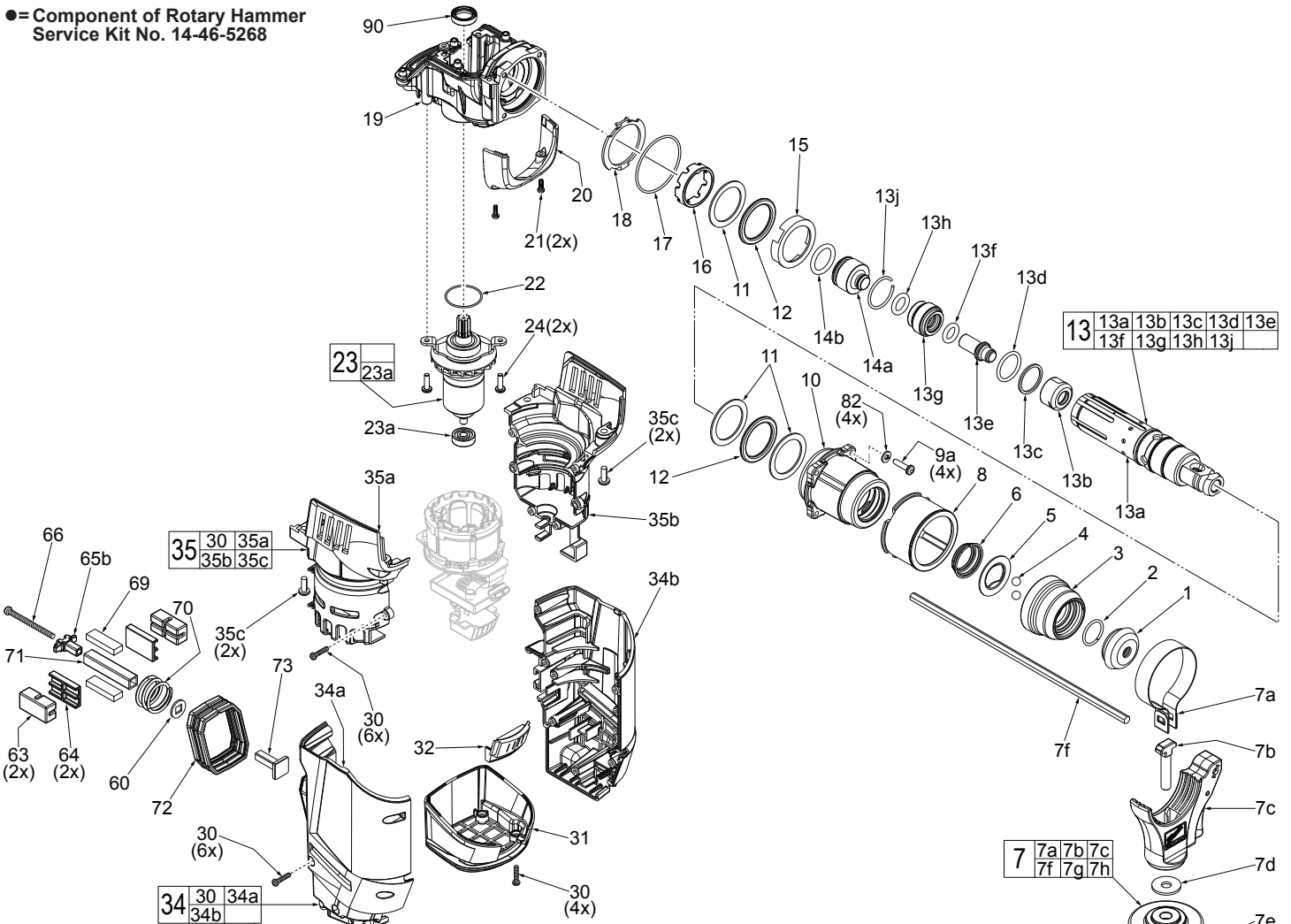

FIG. PART NO. DESCRIPTION OF PART NO. REQ.

FIG.	PART NO.	DESCRIPTION OF PART	NO. REQ.
1	45-12-0045	● Dust Shield	1
2	44-90-5262	● Retaining Ring	1
3	45-22-0062	Collar with Steel Insert	1
4	02-02-0275	● 7mm Steel Ball	2
5	42-36-0017	● Ball Support Plate	1
6	40-50-0082	Conical Spring	1
7	14-34-0015	Side Handle Assembly	1
7a	44-66-0072	Clamp Collar	1
7b	05-81-5376	M8 x 53mm Screw	1
7c	-----	Side Handle Carrier Assembly	1
7d	45-88-5377	Washer	1
7e	31-05-0015	Side Handle	1
7f	44-94-5381	Depth Rod	1
8	45-22-0045	Side Handle Sleeve	1
9a	05-78-5316	M4 x 14mm Pan Hd. Taptite T-20 Screw	4
10	42-40-0127	Bushing Sleeve Assembly with Seals	1
11	45-88-0157	Washer	3
12	45-38-0127	● Bumper	2
13	14-46-0197	Spindle Assembly	1
13a	38-50-0052	Spindle	1
13b	43-06-0060	Brake Ring	1
13c	44-66-0203	Anvil Ring	1
13d	34-40-0032	● Square O-Ring	1
13e	42-06-0027	Anvil/Striker	1
13f	34-40-0052	● Anvil O-Ring	1
13g	42-06-0067	Ram Catcher	1
13h	44-90-0032	● Back Pressure Ring	1
13j	34-60-0027	● Anvil Retaining Ring	1
14a	45-56-0065	Ram	1
14b	34-40-0068	● O-Ring (1 on Ram #14a, 1 on Piston #42b)	2
15	45-88-0042	Bumper/Washer Holder	1
16	42-76-0037	Spindle Collar	1
17	34-40-0082	● O-Ring	1
18	44-60-0119	Retaining Plate	1
★ 19	14-29-0031	Gearbox Assembly	1

FIG. PART NO. DESCRIPTION NO. REQ.

FIG.	PART NO.	DESCRIPTION	NO. REQ.
20	31-15-0033	Shroud	1
21	05-86-1000	M3 x 9.5mm Pan Hd. Taptite T-10 Screw	2
22	34-40-5320	● O-Ring	1
23	16-07-2715	Rotor Assembly	1
23a	02-04-5382	Ball Bearing	1
24	05-78-0105	M4 x 10mm Pan Hd. Taptite Screw	2
30	06-82-2025	M3.5 x 16mm Pan Hd. Plast. T-10 (15 of 23)	23
31	23-44-2715	Bottom Cap	1
32	42-28-0077	Bottom Cap/Connector Rubber	1
34	31-44-2715	Housing Assembly	1
34a	-----	Housing Cover (Right Housing)	1
34b	-----	Housing Support (Left Housing)	1
★ 35	31-50-2716	Motor Housing Assembly	1
35a	-----	Motor Housing Cover (Right Motor Housing)	1
35b	-----	Motor Housing Support (Left Motor Housing)	1
35c	05-74-0990	M5 x 15mm Taptite T-25 Screw	4
60	45-88-0153	Vibration Washer (1 of 2)	2
63	42-38-0077	Vibration Bumper (2 of 4)	4
64	42-38-0137	Bumper Holder (2 of 4)	4
65b	44-66-0131	Retaining Plate	1
66	05-78-0012	M4 x 52mm Scr. (1 each for top & bottom AVS)	2
69	44-52-0052	Foam Block	2
70	40-50-0138	Bottom AVS Spring	1
71	44-68-0155	Bottom AVS Square Guide Pipe	1
72	22-90-0153	Bottom Bellows	1
73	42-36-2715	T-Bracket	1
79	12-20-0043	Service Nameplate (Not Shown)	1
82	05-90-0225	Lock Washer	4
90	45-06-0148	Motor Seal	1

**IMPORTANT:**  
Dimpled end of connecting rod to crank assembly.

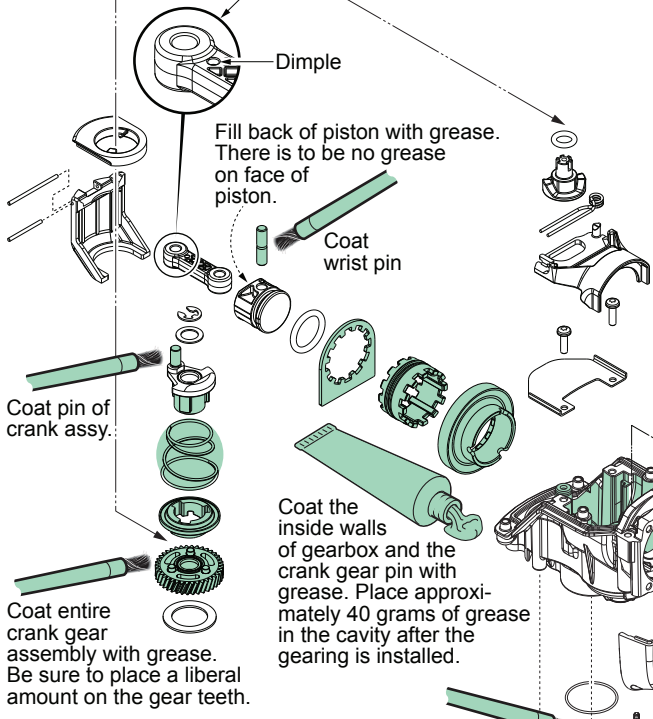

**LUBRICATION NOTES:**  
**Urethyn GE00 Grease**

**No. 49-08-5355, 2.8oz. / 80g tube**

A total of approx. 60 grams will be used. Prior to reinstalling, clean gear assemblies with a clean, dry cloth. Lightly coat all parts highlighted here with Urethyn GE00 grease. Apply a greater amount of grease to all internal and external gear teeth.

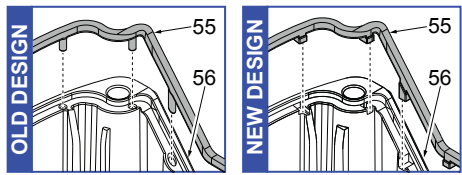
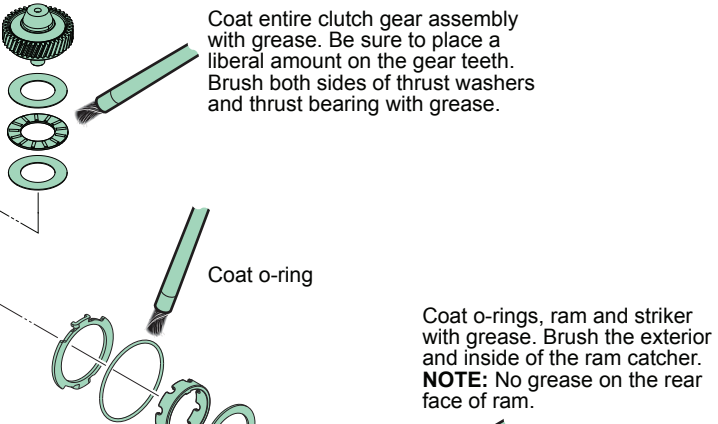

**Bottom View of Gear Case Cover #56 with Gasket #55-** There are two gaskets in Service Kit 14-46-5268. Visually inspect gear case cover to determine which gasket to install. Discard the other gasket.

●14-46-5268

**Rotary Hammer Service Kit**

(For the 0757-20 M28 FUEL™ Rotary Hammer and the 2715-20 M18 FUEL™ Rotary Hammer)

1	42-12-0045	Dust Shield	(1)
2	44-90-5262	Retaining Ring	(1)
4	02-02-0275	7mm Steel Ball	(2)
5	42-36-0017	Ball Support Plate	(1)
12	42-38-0127	Bumper	(2)
13d	34-40-0032	Square O-Ring	(1)
13f	34-40-0052	Anvil O-Ring	(1)
13h	44-90-0032	Back Pressure Ring	(1)
13j	34-60-0027	Anvil Retaining Ring	(1)
14b	34-40-0068	O-Ring	(2)
17	34-40-0082	O-Ring	(1)
22	34-40-5320	O-Ring	(1)
42	42-70-5268	Retaining E-Ring	(1)
54	34-40-0093	O-Ring	(1)
55	42-92-0052	Gearcase Gasket (See detail above)	(1)
55	42-92-0053	Gearcase Gasket (See detail above)	(1)
83	45-88-0014	Rubber Washer	(2)
	58-22-5268	Instruction Sheet	(1)
	49-08-5355	Urethyn GE00 Grease 60 grams required- (80 gram, 2.8oz tube)	(1)
Disregard and discard Carbon Brushes for models 0757-20 and 2715-20.			
22-18-5268	120V Carbon Brush (Set of 2)		(1)
22-18-5268	120V Carbon Brush (Set of 2)		(1)

**DISCARD**

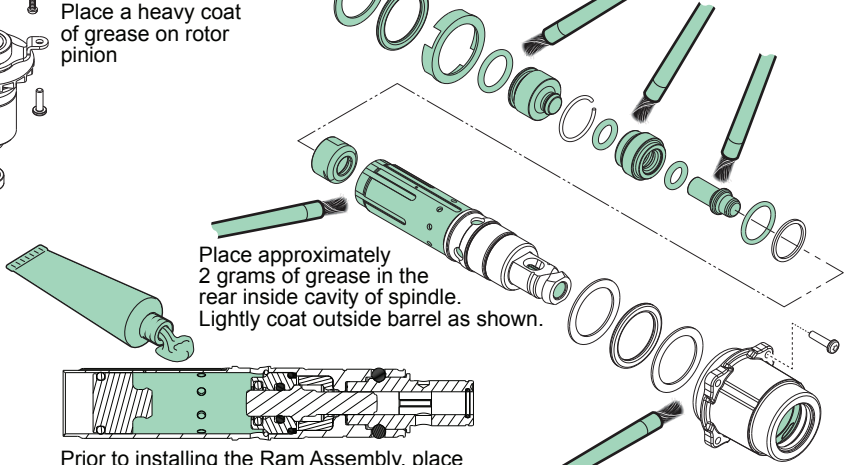

Prior to installing the Ram Assembly, place 18 grams of grease inside of spindle between the ram catcher and the ram

Prior to installing spindle assembly, place a heavy coating of grease in the interior cavity of bushing/sleeve assembly.

**SCREW TORQUE SPECIFICATIONS**

FIG.	PART NO.	WHERE USED	SEAT TORQUE	
			(KG/CM)	(IN/LBS)
9	06-75-2408	Gearcase Cover (4) Rear and Middle	32	27.8
9	06-75-2408	Gearcase Cover (2) Front	32	27.8
9a	05-78-5316	Bushing Sleeve Assembly	26	22.5
21	05-86-1000	Shroud	12	10.5
24	05-78-0105	Clamp Plate	26	22.5
24	05-78-0105	Rotor Bearing Plate	33	28.5
30	06-82-2025	Bottom Cap	12	10.5
30	06-82-2025	Housing Cover	12	10.5
30	06-82-2025	Motor Housing Cover	12	10.5
30	06-82-2025	Right Handle Halve	12	10.5
35c	05-74-0990	Motor Housing Assembly	43	37.5
58	06-82-2025	Selector Knob	8.5	7.5
66	05-78-0012	Retaining Plate (Top and Bottom)	20	17.5

**NOTE:**  
It is recommended to order Motor Seal #90 (45-06-0148) at the same time that Rotary Hammer Service Kit No. 14-46-5268 is installed.



**NOTE:** As an aid to working on the gearcase and spindle assemblies, a bench top fixture can be made from a 3.25" piece of 4" PVC pipe. The contour of the pipe can be cut according to dimensions in the illustration.

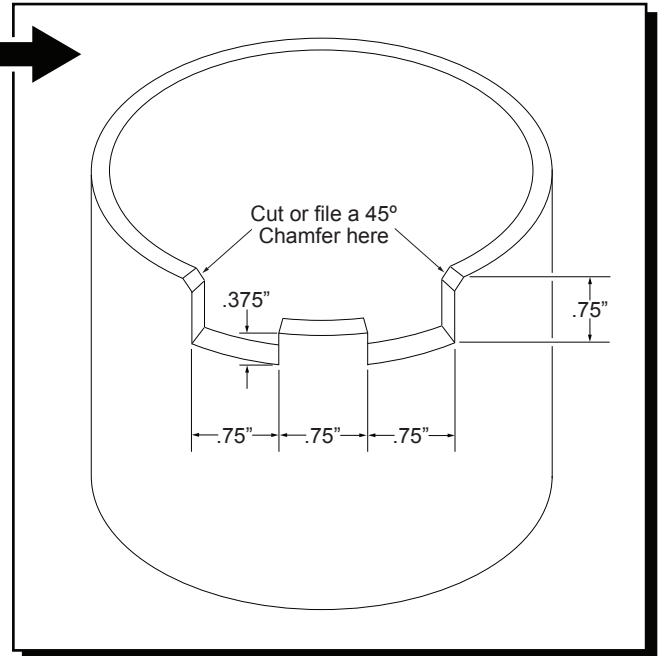

**SERVICE TOOLS:**

**61-10-0041**  
Ring Expander  
Cone

**61-10-0043**  
Push Sleeve

**61-10-0045**  
Seal Press Pin

**61-10-0049**  
Anvil Sleeve  
Snap Ring Bar

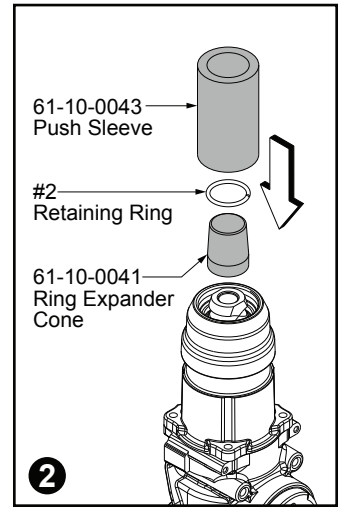
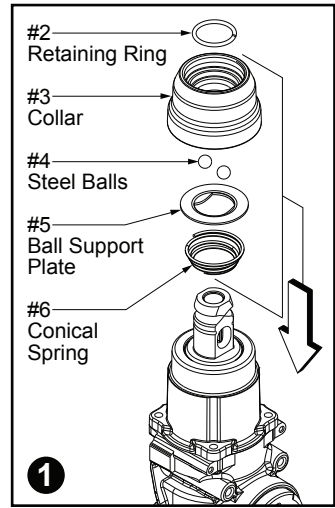
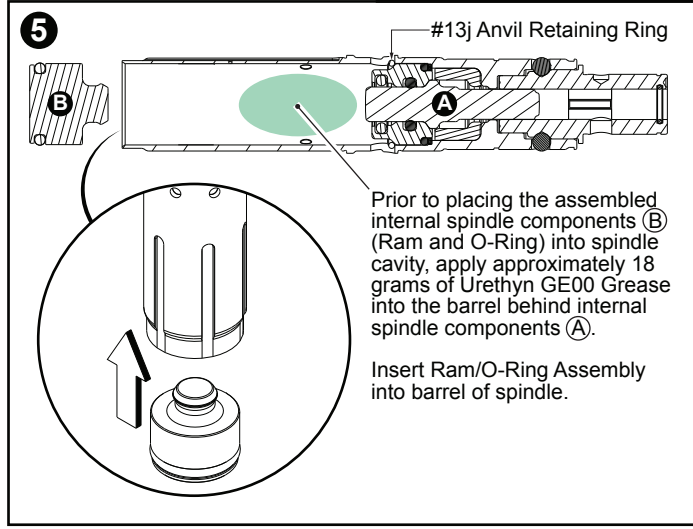
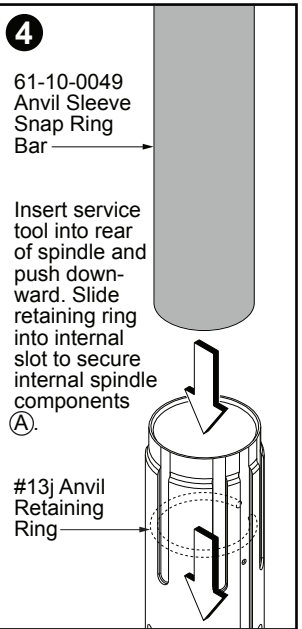
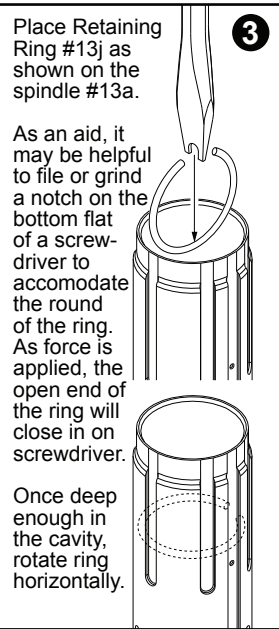
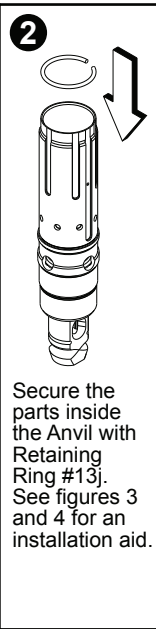
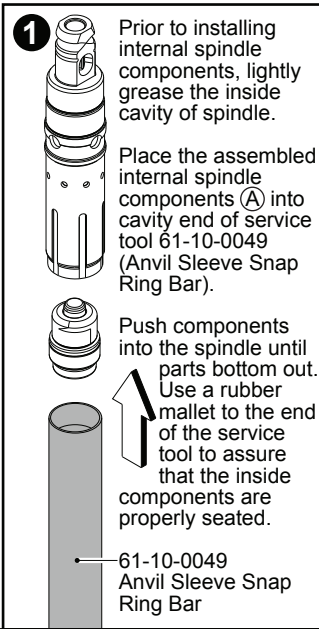
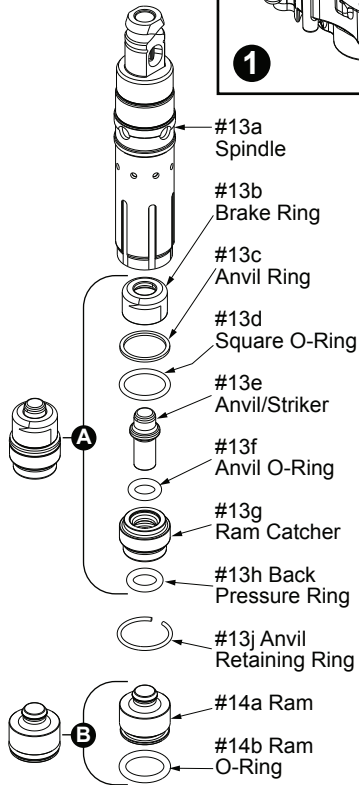
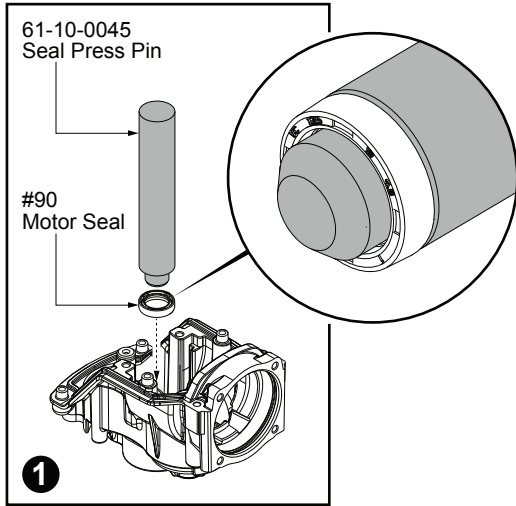

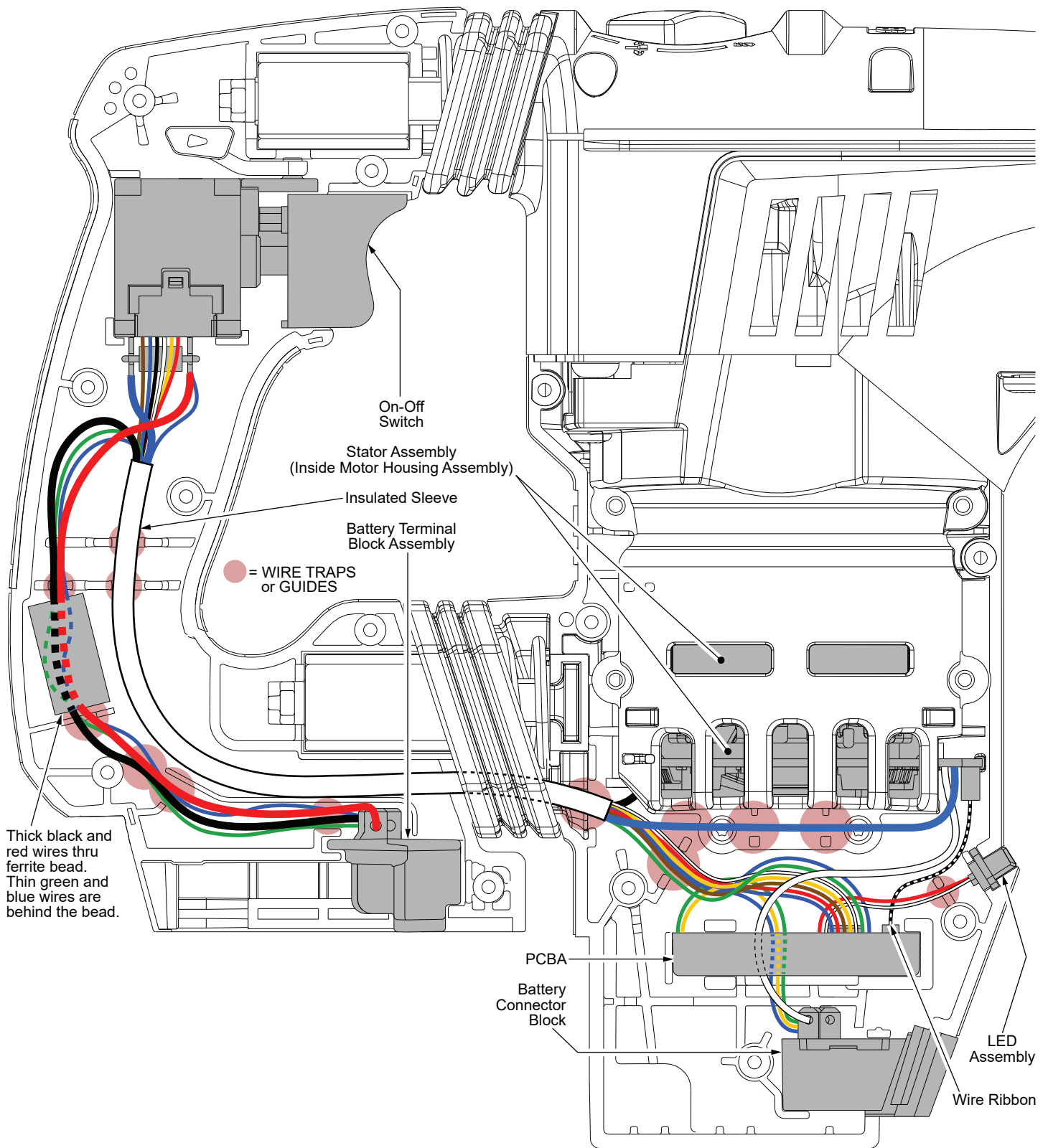

**AS AN AID TO REASSEMBLY, TAKE NOTICE OF WIRE ROUTING AND POSITION IN WIRE GUIDES AND TRAPS WHILE DISMANTLING TOOL.**

**BE SURE THAT ALL COMPONENTS OF THE ELECTRONICS KIT ARE SEATED FIRMLY AND SQUARELY IN THE HOUSING RECESSES.**

**AVOID PINCHED WIRES, BE SURE THAT ALL WIRES AND SLEEVES ARE PRESSED COMPLETELY DOWN IN WIRE GUIDES AND TRAPS.**

**PRIOR TO INSTALLING THE HOUSING COVER ONTO THE HOUSING SUPPORT, BE SURE THAT THERE ARE NO INTERFERENCES.**