



SERVICE PARTS LIST

BULLETIN NO.
54-06-2360

SPECIFY CATALOG NO. AND SERIAL NO. WHEN ORDERING PARTS		REVISED BULLETIN	DATE
CORDLESS M18™ LED FLOODLIGHT			May 2018
CATALOG NO.	2361-20	STARTING SERIAL NO.	F47A
WIRING INSTRUCTION			

EXAMPLE:
00 0 Component Parts (Small #)
Are Included When Ordering
The Assembly (Large #).

NOTE:
Model 2361-20 M18™ LED Floodlight (Serial Break 'A') is designed to operate off of several different M18 REDLITHIUM™ battery sizes from 1.5 amp-hours to 9.0 amp-hours.

To power a 2361-20 M18™ LED Floodlight (serial break 'A') with a 48-11-1812 M18™ REDLITHIUM™ 12.0 amp-hour battery, 12.0 Upgrade Service Kit 14-46-0088 must be ordered to accommodate the larger size battery.

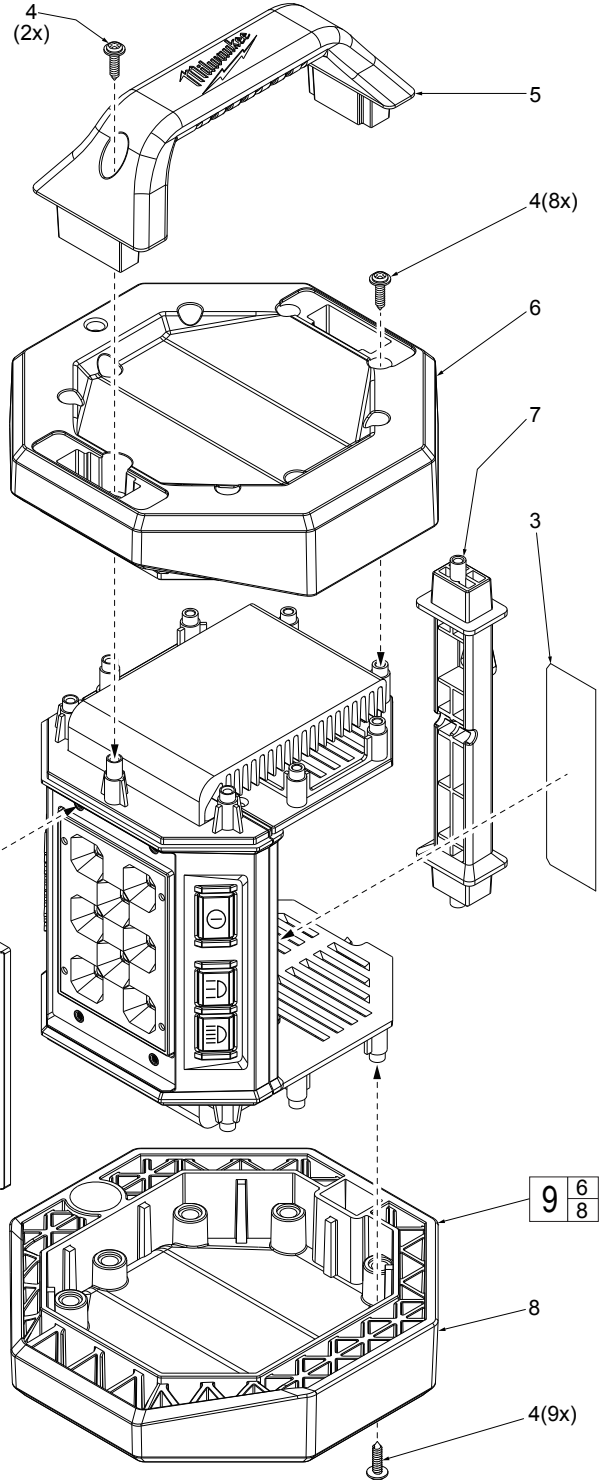
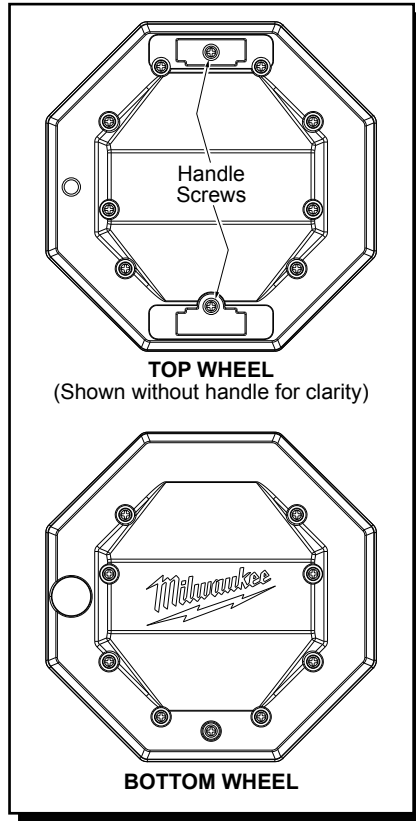

FIG. NOTES

- 1,2 Care must be used when securing screws (1) in tool. To prevent damage to the lens assembly (2) do not over tighten. It *is not* recommended to use power tools, hand tighten only. Torque screws to 3-4 in/lbs (3.5-4.5 kg/cm).
- 3 A clean, dry surface is essential for proper performance for any adhesive system. The area intended for application of any adhesive label or nameplate must be prepared by cleaning with isopropyl alcohol. The solvent is to be applied with a clean, lint free applicator and the surface allowed to dry before applying the label or nameplate.
- 6,8 **NOTE:** As an aid to reassembly, do not attempt to install the top or bottom wheels with screws in the screw cavities. Be sure the wheels are squarely and firmly seated prior to securing with the fasteners.
- 4 Care must be used when securing housing screws (4) in tool. To prevent damage to the main housing, be sure the pointed tip of the fasteners are in the screw boss holes and that the screw is perpendicular to the bosses. It *is not* recommended to use power tools, hand tighten only. Torque screws to 8-10.5 in/lbs (9.5-12 kg/cm).

FIG.	PART NO.	DESCRIPTION OF PART	NO. REQ.
1	05-81-0625	M3 x 8mm Pan Hd. T-10 Screw	(4)
2	-----	Lens Assembly	(1)
3	12-20-2361	Service Nameplate	(1)
4	06-82-0022	M3.5 x 8mm Pan Hd. Washer Plast. T-10 Sc	(19)
5	31-44-0995	Top Handle	(1)
6	-----	Top Wheel	(1)
7	31-01-1585	Hang Bar	(1)
8	-----	Bottom Wheel	(1)
9	31-70-2361	Wheel Kit	(1)
10	44-06-0240	Lens Assembly Kit	(1)