



SERVICE PARTS LIST

BULLETIN NO.
54-05-0135

SPECIFY CATALOG NO. AND SERIAL NO. WHEN ORDERING PARTS		REVISED BULLETIN	DATE
M18™ FUEL™ 6 GALLON WET/DRY VACUUM			Dec. 2021
CATALOG NO.	0910-20	STARTING SERIAL NO.	L63A
			WIRING INSTRUCTION See page 3

EXAMPLE:
00 | 0
Component Parts (Small #) Are Included
When Ordering The Assembly (Large #).

FIG.	PART NO.	DESCRIPTION OF PART	NO. REQ.
13	49-90-1987	Wand (Includes 1)	(2)
14	-----	6 Gallon Tank (See item 73)	(1)
15	42-16-2700	Bag Holder Attachment	(1)
16	42-16-2705	Bag Holder Screw-In Attachment	(1)
17	44-85-0252	Tank Foot #1	(2)
18	05-74-1044	M4 x 12mm Flange T-15 Screw	(10)
19	-----	Cart Base	(1)
20	14-04-0130	Caster	(4)
21	44-85-0253	Tank Foot #2	(2)
22	31-01-3035	Drain Cap	(1)
23	-----	Pedal Cover	(1)
24	40-50-3925	Spring	(1)
25	05-74-1046	M4 x 12mm Self-Tapping T-15 Screw	(2)
26	45-06-0589	Tank Handle	(2)
27	45-24-3100	Pedal	(1)
71	49-90-1996	Hose Assembly	(1)
72	0923-20	Cart Base Assembly	(1)
73	0922-20	Tank Assembly	(1)

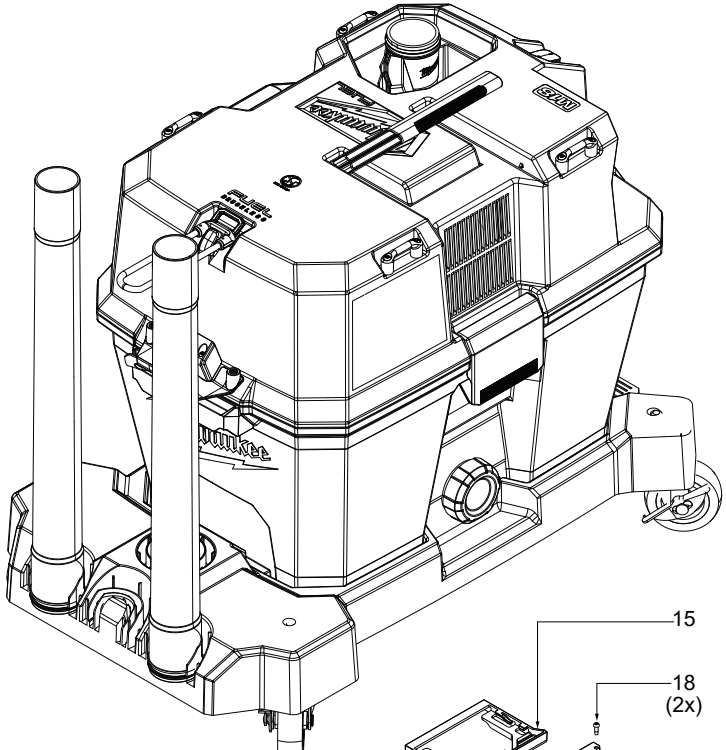

See page two for Head Assembly service parts and a Torque Specification Chart for fasteners

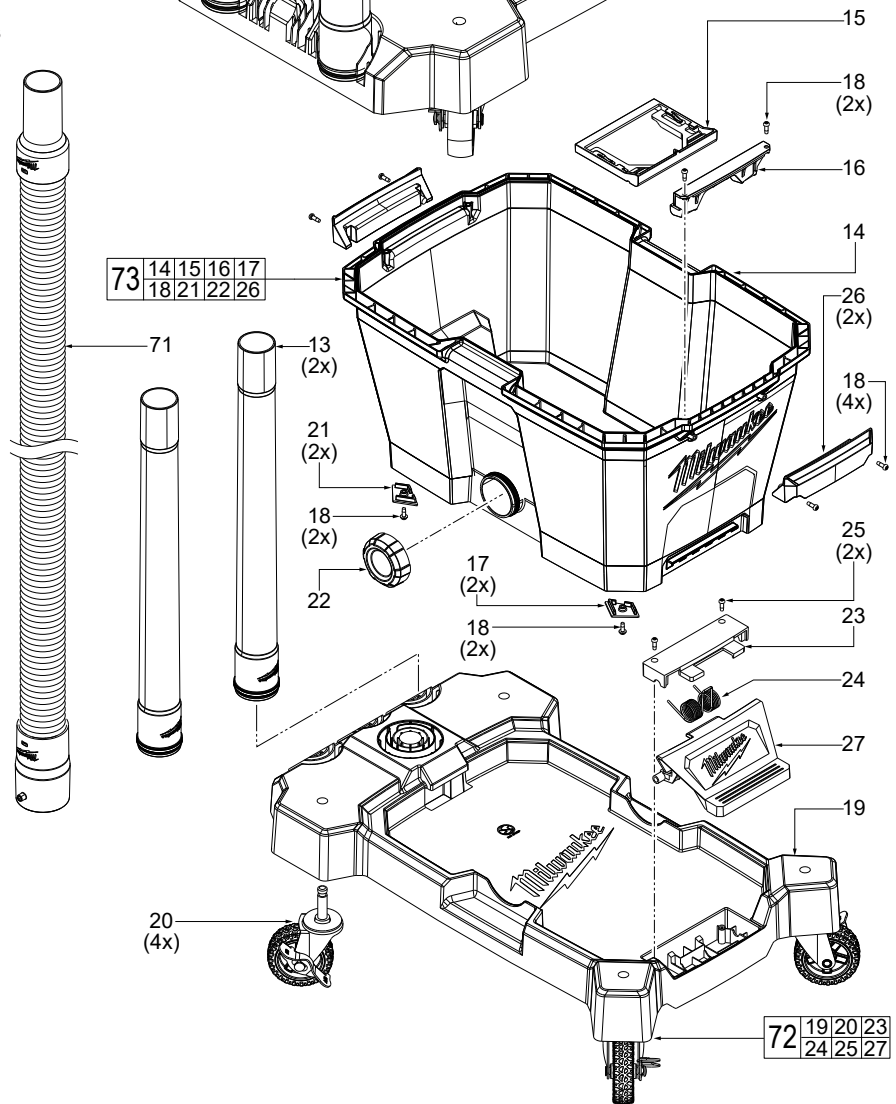
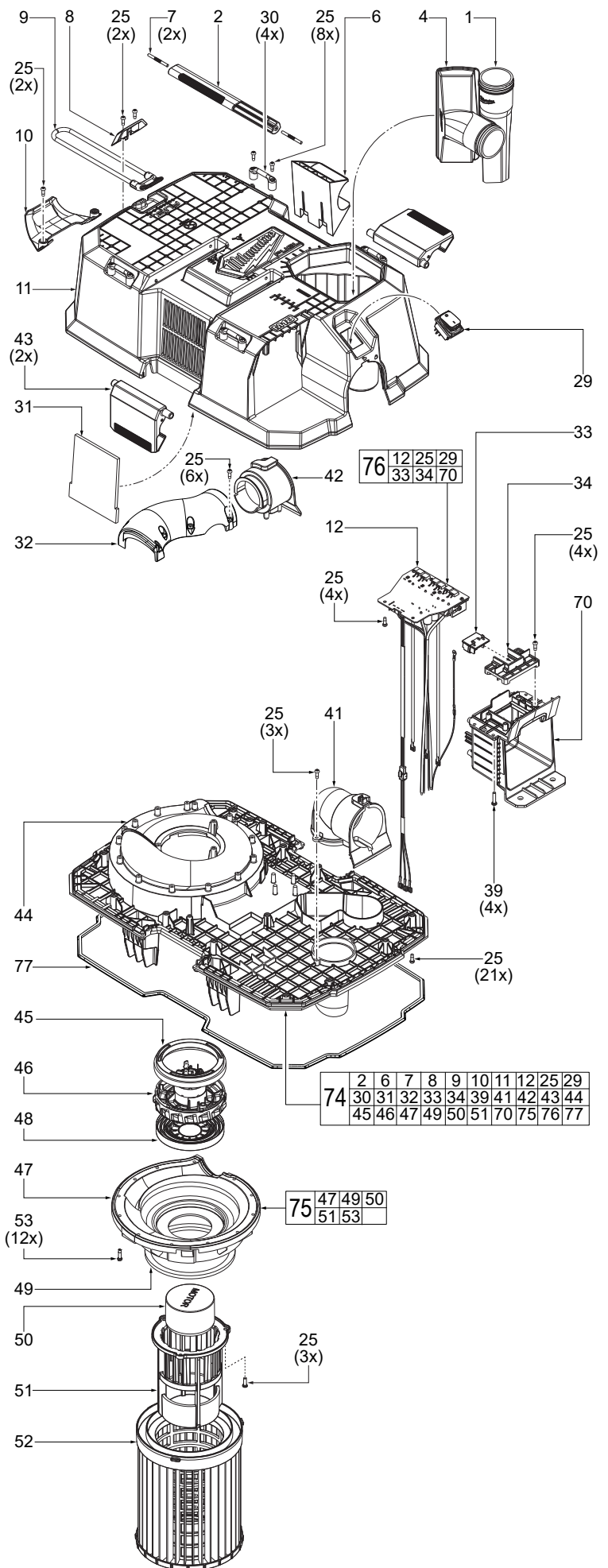
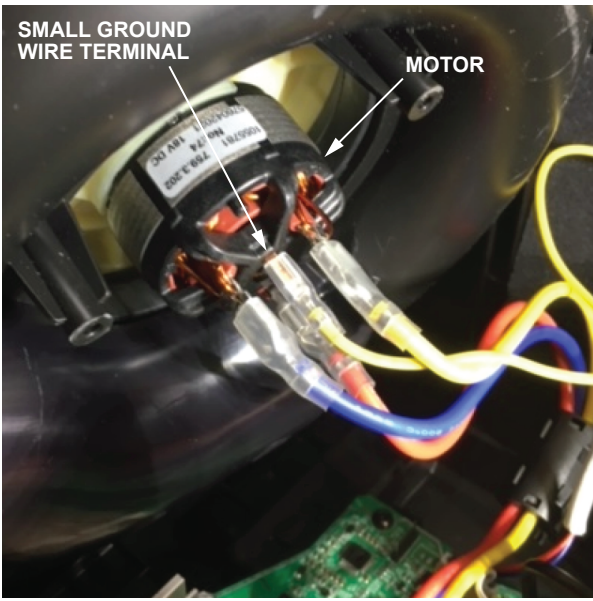

FIG.	PART NO.	DESCRIPTION OF PART	NO. REQ.
1	49-90-1988	Crevice Tool	(1)
2	31-44-7015	Carrying Handle	(1)
4	49-90-2011	Floor Utility Nozzle	(1)
6	42-28-0506	Hose Clip	(1)
7	31-44-7017	Knurled Pin	(2)
8	42-28-0560	Bungee Holder	(1)
9	14-37-0185	Bungee Hose Strap	(1)
10	31-70-0170	Hose Rest Bracket	(1)
11	-----	Head	(1)
12	-----	PCBA	(1)
25	05-74-1046	M4 x 12mm Self-Tapping T-15 Screw	(53)
29	23-66-1987	On-Off Switch	(1)
30	45-58-0285	Mounting Cleat (Set of 1)	(4)
31	58-95-0075	Foam, Head	(1)
32	31-01-3030	Exhaust Cover	(1)
33	-----	Battery Terminal Block	(2)
34	31-01-3020	Battery Terminal Cap	(1)
39	05-74-1042	#7-18 x 19mm Plastite T-20 Screw	(4)
41	43-33-0480	Inlet Elbow	(1)
42	31-05-0735	Exhaust Port	(1)
43	45-06-0585	Tank Buckle	(2)
44	31-01-1008	Mid-Frame	(1)
45	44-66-5364	Motor Isolator-Upper	(1)
46	31-50-9000	Motor Assembly	(1)
47	-----	Lower Volute	(1)
48	31-55-0245	Motor Isolator-Lower	(1)
49	-----	Lower Volute Filter Seal	(1)
50	-----	Ball Float	(1)
51	-----	Ball Float Cage	(1)
52	49-90-1978	Large Wet/Dry Vacuum High Efficiency Filter	(1)
53	05-74-0222	M4 x 16mm Self-Tapping T-20 Screw	(12)
70	31-44-0461	Battery Housing with Left Rail	(1)
74	0911-20	Head Assembly	(1)
75	31-15-1987	Lower Volute/Float Cage Assembly	(1)
76	23-66-6520	Electronics Assembly	(1)
77	45-06-0587	Mid-Frame Gasket	(1)
	49-90-1979	Fleece Dust Bags (Pkg. of 5) (Not Included)	(1)



SCREW TORQUE SPECIFICATIONS

FIG.	PART NO.	WHERE USED	SEAT TORQUE	
			(KG/CM)	(IN/LBS)
Page 1				
18	05-74-1044	Tank Foot #1 (17)	4.38±1	3.8±1
18	05-74-1044	Tank Foot #2 (21)	4.38±1	3.8±1
18	05-74-1044	Bag Holder (16)	8.06±1	7.0±1
25	05-74-1046	Pedal Cover (23)	8.06±1	7.0±1
18	05-74-1044	Tank Handle (26)	8.06±1	7.0±1
Page 2				
25	05-74-1046	Bungee Holder (8)	8.06±1	7.0±1
25	05-74-1046	PCBA (12)	6.91±1	6.0±1
25	05-74-1046	Mounting Cleat (30)	6.91±1	6.0±1
25	05-74-1046	Exhaust Cover (32)	8.06±1	7.0±1
25	05-74-1046	Battery Term. Cap (34)	8.06±1	7.0±1
25	05-74-1046	Inlet Elbow (41)	8.06±1	7.0±1
25	05-74-1046	Mid-Frame (44)	8.06±1	7.0±1
25	05-74-1046	Ball Float Cage (51)	8.06±1	7.0±1
39	05-74-1042	Battery Hsg. Assy. (70)	10.36±1	9.0±1
53	05-74-0222	Lower Volute (47)	8.06±1	7.0±1



- Connect Yellow Ground PCBA wire to smallest terminal on the motor.
 - Connect Red PCBA wire to terminal labeled RED on the upper right of motor.
 - Connect Yellow PCBA wire to terminal labeled YLW on the upper left of motor.
 - Connect Blue PCBA wire to terminal labeled BLU on the bottom of motor.
 - * Pull on all wires terminated at the motor to ensure proper connection.
- Join PCBA wires and On-Off Switch wires by inserting connector ends together.

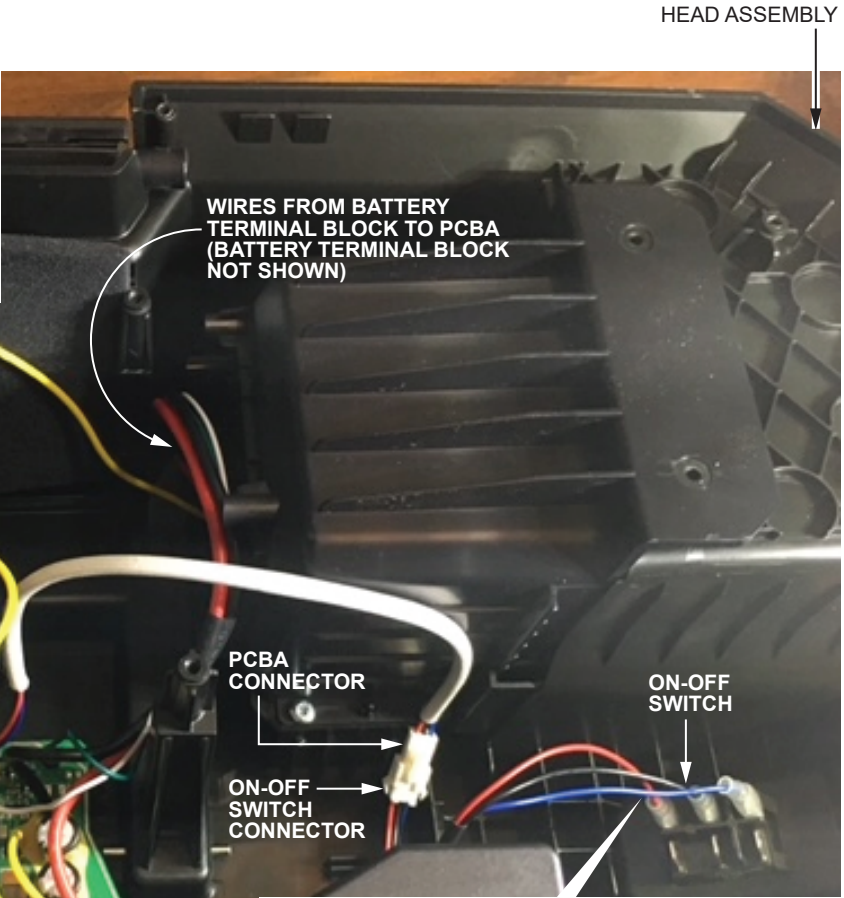
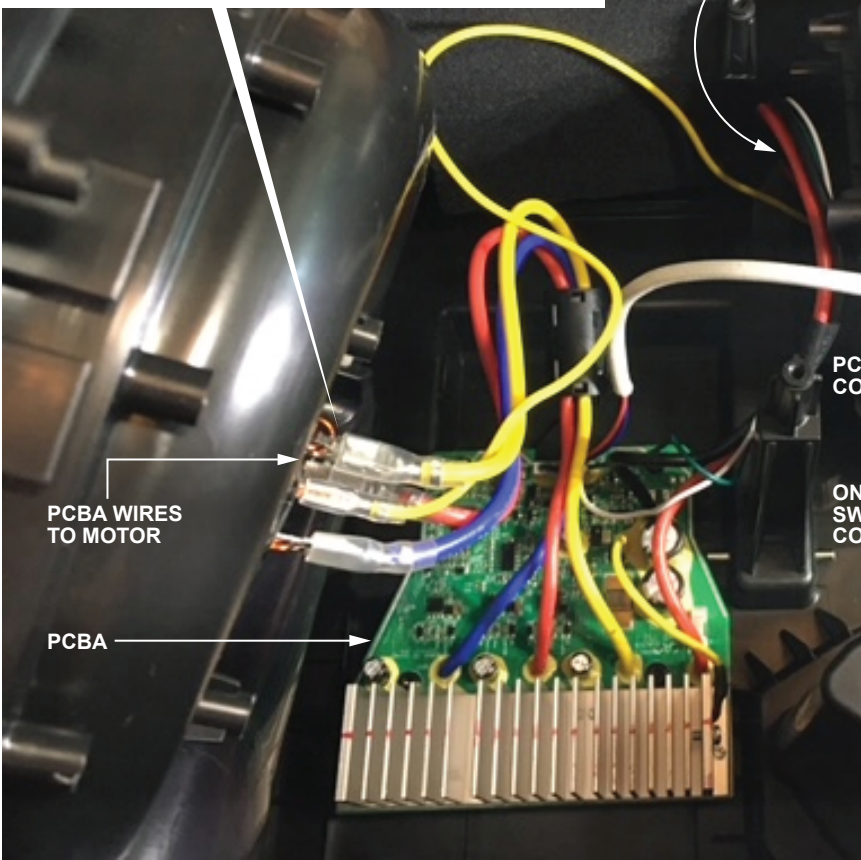

MID-FRAME

As an aid to reassembly, take notice of wire routings and position in wire guides and traps while dismantling tool.

Be sure that all components of electronics kit are seated firmly and squarely in housing recesses.

Avoid pinched wires, be sure that all wires and sleeves are pressed completely down in wire traps.

Prior to securing mid-frame onto the head, be sure that there are no interferences.

Before installing the battery, check for proper functionality of switch.

Install battery and depress switch triggers to assure tool is operating properly.

