



SERVICE PARTS LIST

BULLETIN NO.
54-00-2769

SPECIFY CATALOG NO. AND SERIAL NO. WHEN ORDERING PARTS		REVISED BULLETIN	DATE
M18™ FUEL™ ONE KEY™ 1/2" EXT. ANVIL HTIW			July 2019
CATALOG NO.	2769-20	STARTING SERIAL	K94A
WIRING INSTRUCTION			

EXAMPLE:
Component Parts (Small #)
Are Included When Ordering
The Assembly (Large #).

00 0

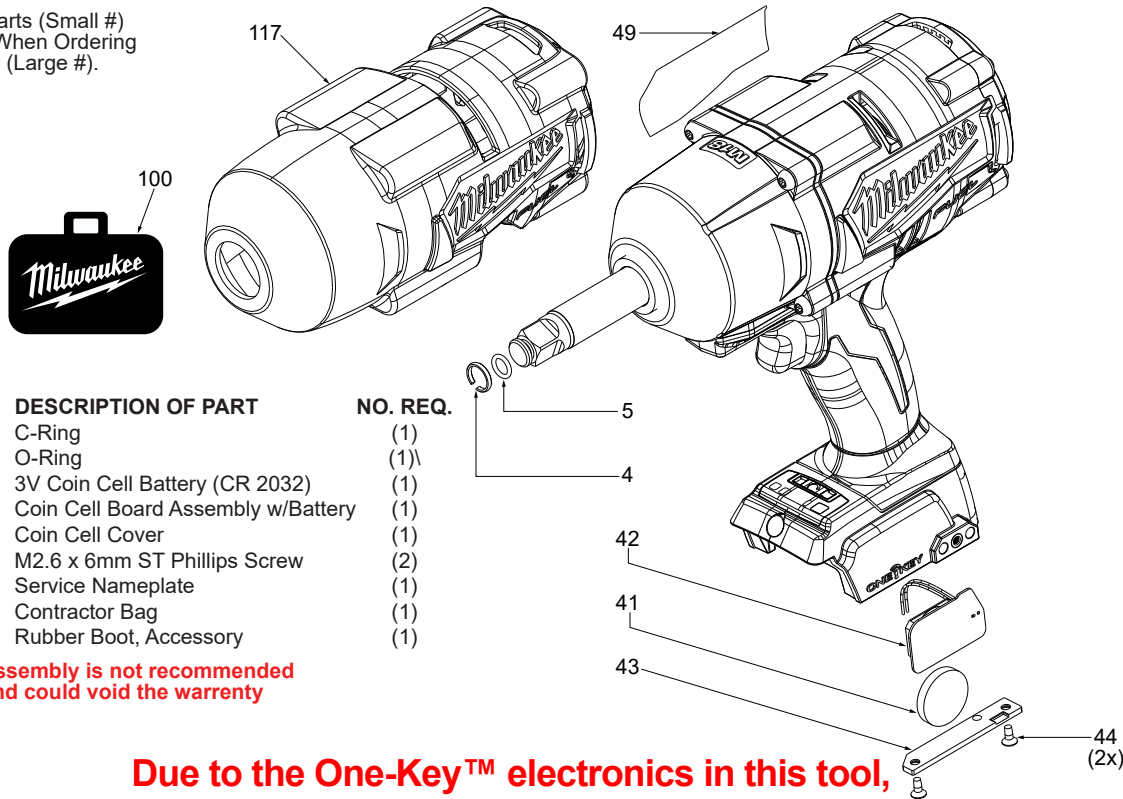

FIG.	PART NO.	DESCRIPTION OF PART	NO. REQ.
4	44-90-4530	C-Ring	(1)
5	34-40-0900	O-Ring	(1)
41	50-11-0020	3V Coin Cell Battery (CR 2032)	(1)
42	22-09-2757	Coin Cell Board Assembly w/Battery	(1)
43	31-15-0011	Coin Cell Cover	(1)
44	05-81-1100	M2.6 x 6mm ST Phillips Screw	(2)
49	12-20-2810	Service Nameplate	(1)
100	42-55-2866	Contractor Bag	(1)
117	49-16-2767	Rubber Boot, Accessory	(1)

**Disassembly is not recommended
and could void the warranty**

**Due to the One-Key™ electronics in this tool,
service can only be performed at Milwaukee Authorized Hydraulic Repair Centers:**

MILWAUKEE TOOL Central Repair
1401 Sycamore Avenue • Greenwood, MS 38930-7277
Please send your tool directly to this location for service.

Or

Via e-Service at: www.milwaukeetool.com/e-service
questions, please call 1.800.SAWDUST (1.800.729.3878)

Or

Visit www.milwaukeetool.com to find your closest
Milwaukee authorized Hydraulic repair center

Or

Return it to a MILWAUKEE *factory* Service Center location, freight prepaid and insured.
A copy of the proof of purchase should be included with the return product.

If you have questions please contact Milwaukee Product Service at:

Product Technical Support via phone at: 262.783.8642

Or

Via email at: METProductSupport@milwaukeetool.com