



PED50B BRONZE PEDESTAL SUMP PUMP

FEATURES

- Column style sump pumps for sumps with a minimum 11" in diameter and maximum 24" deep.
- Continuous duty rated PSC motor; higher efficiency.
- Top mounted adjustable vertical switch

***Honest
Professional
Dependable***

1899 Cottage Street, Ashland, Ohio 44805

Telephone: 855 281-6830 · Fax: 877 326-1994

ashlandpump.com



PED50B - 1/2 Bronze Pedestal Sump Pump

TECHNICAL DATA

Physical Data:

DISCHARGE SIZE **1-1/4" NPT (1-1/2" Adapter)**
 IMPELLER TYPE **Vortex- Stainless Steel**
 CABLE LENGTH **8'**

Liquid Handling:

SOLIDS SIZE **3/16"**
 MAXIMUM LIQUID TEMP. **104°F - Intermittent**
 ACCEPTABLE PH RANGE **6-8**

Temperature:

MAXIMUM STATOR **130°C**

Technical Data:

POWER CORD TYPE **SJT**
 MOTOR HOUSING **Steel**
 CASING **Bronze**
 IMPELLER **Stainless Steel**
 MOTOR SHAFT **Stainless Steel**
 HARDWARE **SST**
 "O" RINGS **NBR**
 SEAL **LIP**
 UPPER BEARING **6202**
 LOWER BEARING **6202**

ELECTRICAL DATA

R.P.M. **1750**
 MOTOR TYPE **PSC**
 GENERAL INSULATION CLASS **B**
 STATOR WINDING CLASS **B**
 MAXIMUM STATOR TEMPERATURE **130°C**
 VOLTAGE TOLERANCE **±10%**
 MOTOR PROTECTION **Thermally Protected**
 HP **1/2**
 VOLTAGE **115**
 PHASE **1**
 SERVICE FACTOR **1.0**
 FULL LOAD AMPS **5.2**

DIMENSIONAL DATA

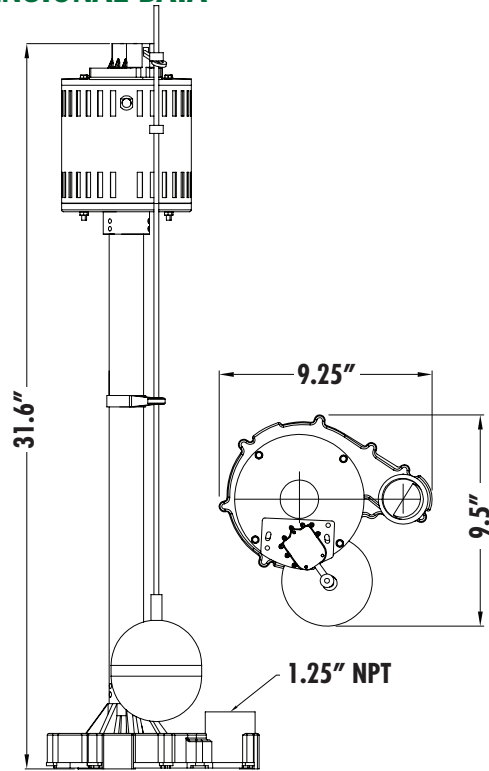

PERFORMANCE CURVE

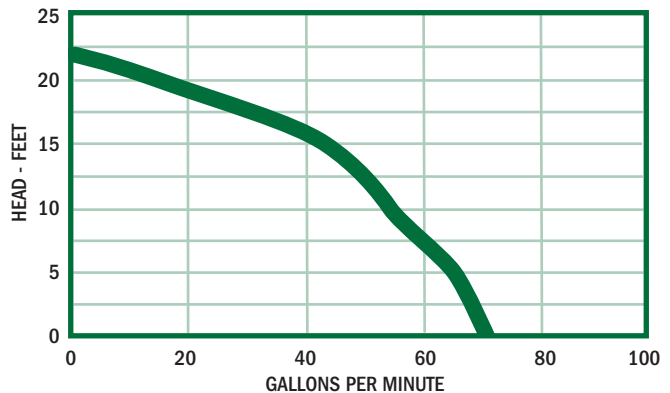

PERFORMANCE CHART

Total Lift(feet)	0	5	10	15	20	22
GPM	70	65	58	43	15	0

Ashland

P U M P

Honest, Professional, Dependable

1899 Cottage Street, Ashland, Ohio 44805

Telephone: 855 281-6830 · Fax: 877 326-1994 · ashlandpump.com